

Note that the processor counts in Planar-1 and Planar-2 refer to distinct models of computation: the processors for Planar-2 must have unit cost multiplication, while those in Planar-1 are essentially bit processors.

REFERENCES

- [Br] R. P. BRENT, *The parallel evaluation of general arithmetic expressions*, J. Assoc. Comput. Mach., 21 (1974), pp. 201-206.
- [BL] K. S. BOOTH AND G. S. LUEKER, *Testing for the consecutive ones property, interval graphs and graph planarity using PQ-tree algorithms*, J. Comp. System. Sci., 13 (1976) pp. 335-379.
- [BM] J. A. BONDY AND U. S. R. MURTY, *Graph Theory with Applications*, American Elsevier, New York, 1977.
- [C] L. CSANKY, *Fast parallel matrix inversion algorithms*, this Journal, 5 (1976), pp. 618-623.
- [Ch] A. K. CHANDRA, *Maximal parallelism in matrix multiplication*, IBM Tech. Rep. RC 6193, Sept. 1976.
- [Ev] S. EVEN, *Graph Algorithms*, Computer Science Press, Rockville, MD, 1979.
- [F] M. J. FLYNN, *Vary high-speed computing systems*, Proc. IEEE, 54 (1976), pp. 1901-1909.
- [FW] S. FORTUNE AND J. WYLLIE, *Parallelism in random access machines*, Proc. 10th Annual ACM Symposium on Theory of Computing, San Diego, CA, 1978, pp. 114-118.
- [G1] C. M. GORDSCHLAGER, *A unified approach to models of synchronous parallel machines*, Proc. 10th Annual ACM Symposium on Theory of Computing, San Diego, CA, 1978, pp. 89-94.
- [G2] F. HARARY, *Graph Theory*, Addison-Wesley, Reading, MA, 1969.
- [H] D. HELLER, *A survey of parallel algorithms in numerical linear algebra*, SIAM Rev., 20 (1978), pp. 740-777.
- [H1] D. C. HIRSCHBERG, *Parallel algorithms for the transitive closure and the connected components problems*, Proc. 8th Annual ACM Symposium on Theory of Computing, 1976, pp. 55-57.
- [HS] J. HARTMANIS AND J. SIMON, *On the power of multiplication in random access machines*, Proc. 15th SWAT Conf., New Orleans, LA, 1974, pp. 13-23.
- [HT] J. E. HORROCKS AND R. E. TARJAN, *Efficient planarity testing*, J. Assoc. Comput. Mach., 21, 4 (1974), pp. 549-568.
- [J] J. JA. JA., *Graph connectivity problems on parallel computers*, Tech. Rep. CS-78-05, Dept. Computer Science, Pennsylvania State Univ., University Park, 1978.
- [JS] J. JA. JA. AND J. SIMON, *Some space-efficient algorithms*, Proc. 17th Attention Conference, 1979, pp. 677-684.
- [McL1] S. McLANE, *A combinatorial condition for planar graphs*, Fundamenta Math., 28 (1937), pp. 22-32.
- [McL2] ———, *A structural characterization of planar combinatorial graphs*, Duke Math. J., 3 (1937), pp. 46-472.
- [P] F. P. PREPARATA, *Parallelism in sorting*, International Conference on Parallel Processing, Beloit, Michigan (August 1977).
- [PS] V. R. PRASAD AND L. J. STOCKMEYER, *A characterization of the power of vector machines*, J. Comput. Systems Sci., 12 (1976), pp. 198-221.
- [PS3] F. P. PREPARATA AND D. V. SARWATE, *An improved parallel processor bound in fast matrix inversion*, IPL, 7, 3 (1978) pp. 148-150.
- [SJ] C. SAVAGE AND J. JA. JA., *Fast, efficient parallel algorithms for some graph problems*, this Journal, 10 (1981), pp. 682-690.
- [T] W. T. TUTTE, *How to draw a graph*, Proc. London Math. Soc., 3, 13 (1965), pp. 743-768.

PLANAR FORMULAE AND THEIR USES*

DAVID LICHTENSTEN†

Abstract. We define the set of planar boolean formulae, and then show that the set of true quantified planar formulae is polynomially space complete and that the set of satisfiable planar formulae is NP-complete. Using these results, we are able to provide simple and nearly uniform proofs of NP-completeness for planar node cover, planar Hamiltonian circuit and line, geometric connected dominating set, and of polynomial space completeness for planar generalized geography.

The NP-completeness of planar node cover and planar Hamiltonian circuit and line were first proved elsewhere [M. R. Garey and D. S. Johnson, *The rectilinear Steiner tree is NP-complete*, SIAM J. Appl. Math., 32 (1977), pp. 826-834] and [M. R. Garey, D. S. Johnson and R. E. Tarjan, *The planar Hamilton circuit problem is NP-complete*, SIAM J. Comp., 5 (1976), pp. 704-714].

Key words. Computational complexity, NP-completeness, P-space-completeness, combinatorial games, planar graphs

1. Motivation. Many properties that are NP-complete for general graphs are also NP-complete for planar graphs. (Others, such as max clique and max cut, are significantly easier to test for on planar graphs, unless $P = NP$.) Proofs of planar NP-completeness often involve two stages, typified by the proof that planar node cover is NP-complete [4]. The first stage is the proof for general graphs, the second is the construction of a complicated crossover box, which is added to the nonplanar reduction everywhere two arcs cross. Unfortunately, such crossover boxes are hard to find and hard to understand.

In this paper, we present a crossover box whose planarity is invariant under many polynomial reductions. In this way, we argue that various planar completeness results are "true for the same reason". Our technique may therefore be a useful tool to use in attempts to strengthen general results to their planar subcases.

2. Preliminaries.

(1) A boolean formula B in conjunctive normal form with at most 3 variables per clause (3CNF) is a set of clauses $B = \{c_1, \dots, c_m\}$. Each clause is a subset of 3 literals from the sets $V = \{v_1, \dots, v_n\}$ and $\bar{V} = \{\bar{v}_1, \dots, \bar{v}_n\}$. For convenience, clauses will be written $(a + b + c)$ instead of $\{a, b, c\}$.

(2) The set of quantified boolean formulae with at most 3 variables per clause (3QBF) = $\{Q_1 v_1 Q_2 v_2 \dots Q_m v_m B(v_1, v_2, \dots, v_m)\}$, where the v_i are boolean variables and B is in 3CNF.

(3) TF is the set of true formulae in 3QBF. We will also refer to the problem of recognizing this set as TF.

(4) 3SAT is the subset of TF where all variables are existentially quantified.

(5) The variable v_i occurs m_i (abbreviated m_i) times, negated or unnegated, in B .

(6) We use as few subscripts as possible, for the sake of readability. Most structures will be described by picture and example, rather than formally.

(7) It will sometimes be convenient to coalesce certain subgraphs into a single macro node. The macro node is then adjacent to all nodes which were originally adjacent to some node in the subgraph replaced by the macro node. This coalescing will be signified pictorially by means of a dotted line around the subgraph.

* Received by the editors January 20, 1978, and in final revised form March 25, 1981.

† Department of Computer Science, Yale University, New Haven, Connecticut 06520. This research was partially supported by the National Science Foundation under grant MCS76-17605.

(8) Each problem in the paper is trivially in NP, except for generalized geography, which is trivially in P-space.

3. Planar formulae. In this section, we prove the main results of the paper, the P-space-completeness of the planar quantified boolean formula problem, and the NP-completeness of planar satisfiability. Since 3SAT is just TF with all variables existentially quantified, the same reduction reduces TF to planar TF and 3SAT to planar 3SAT. TF was shown to be P-space-complete in [9]; 3SAT was shown to be NP-complete in [2].

DEFINITION: Let $B \in \text{Q3CNF}$. We call $G(B) = (N, A)$ the graph of B , where $N = \{c_i | 1 \leq i \leq m\} \cup \{v_i | 1 \leq i \leq n\}$, $A = A_1 \cup A_2$, where

$$A_1 = \{(c_i, v_j) | v_j \in c_i \text{ or } v_j \in \bar{c}_i\}, \quad A_2 = \{(v_i, v_{i-1}) | 1 \leq i < n\} \cup \{(v_m, v_1)\}.$$

Example: $B = (a + \bar{b} + c)(b + \bar{d})$
 Notice that $(a + b + c)$ would give the same graph as $(a + \bar{b} + c)$.

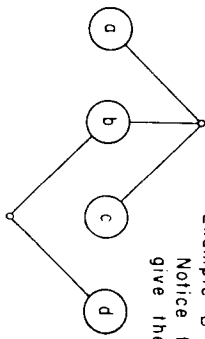

FIG. 1

DEFINITION: The planar quantified boolean formula problem (PTF) is TF restricted to formulae B such that $G(B)$ is planar.

THEOREM 1. PTF is P-space complete.

Proof. We give a polynomial time algorithm that converts a formula B in 3QBF into a formula PB such that:

- (i) $G(PB)$ is planar;
- (ii) $PB \Leftrightarrow B$.

The algorithm proceeds as follows. Draw $G(B)$ on a grid. The grid is $3m \times 3m$, with nodes arranged on the left and bottom borders. The set of clauses $\{c_i\}$ lies along the left border, with each node covering the end points of 3 adjacent horizontal grid lines. The variables $\{v_j\}$ lie along the bottom border, with each node v_j covering the end points of m_j vertical lines of the grid. Grid lines are then darkened in the obvious manner, so that each arc in A_1 consists of a horizontal segment and a vertical segment. A_2 is obtained simply by joining adjacent variables with an arc (see Fig. 2).

We now modify the formula so that nonplanarity is eliminated in A_1 , and then further modify the formula so that A_2 can be drawn without introducing nonplanarity. Pick a point on the graph where two arcs cross, involving, for instance, the variables a and b (see Fig. 3).

Replace that section of the graph by the subgraph shown in Fig. 4, $G(X)$, where the small unlabeled nodes in the picture represent clauses of X . Viewing B as a string, the clauses of X are appended to B , and a new quantifier block existentially quantifying the new variables in X is inserted between the last quantifier of B and the

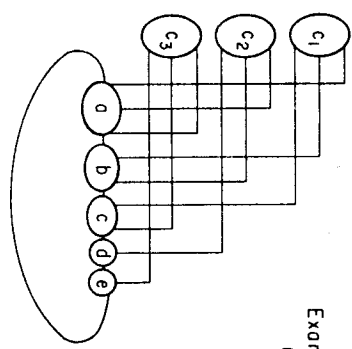

FIG. 2

Example: $B = (a + \bar{b} + c)(a + b + d)(a + \bar{c} + e)$

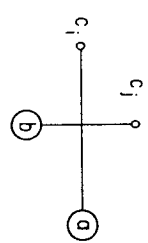

FIG. 3

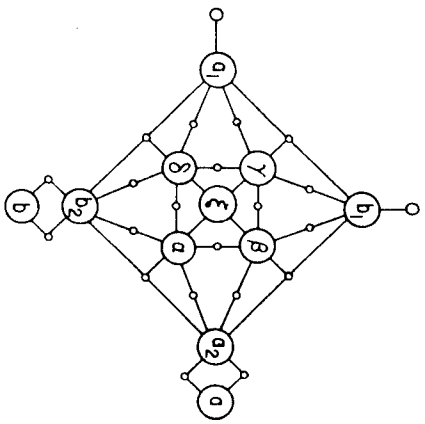

FIG. 4

beginning of the formula. X is comprised of the following!

$$\begin{aligned}
 &(\bar{a}_2 + \bar{b}_2 + \alpha)(a_2 + \bar{a})(b_2 + \bar{a}), \text{ i.e., } a_2 b_2 \Leftrightarrow \alpha; \\
 &(\bar{a}_2 + b_1 + \beta)(a_2 + \bar{\beta})(\bar{b}_1 + \bar{\beta}), \text{ i.e., } a_2 \bar{b}_1 \Leftrightarrow \beta; \\
 &(a_1 + b_1 + \gamma)(\bar{a}_1 + \bar{\gamma})(\bar{b}_1 + \bar{\gamma}), \text{ i.e., } \bar{a}_1 \bar{b}_1 \Leftrightarrow \gamma; \\
 &(a_1 + \bar{b}_2 + \delta)(\bar{a}_1 + \bar{\delta})(b_2 + \bar{\delta}), \text{ i.e., } \bar{a}_1 b_2 \Leftrightarrow \delta; \\
 &(\alpha + \beta + \gamma + \delta); \\
 &(\bar{\alpha} + \bar{\beta})(\bar{\gamma} + \bar{\delta})(\bar{\gamma} + \bar{\delta} + \bar{\alpha}); \\
 &(a_2 + \bar{a})(a + \bar{a}_2)(b_2 + \bar{b})(b + \bar{b}), \text{ i.e., } a \Leftrightarrow a_2, \quad b \Leftrightarrow b_2;
 \end{aligned}$$

and a new quantifier block existentially quantifying the new variables is appended to the list of quantifiers.

At the same time a or \bar{a} is replaced in c_1 with a_1 or \bar{a}_1 and b or \bar{b} is replaced in c_1 with b_1 or \bar{b}_1 .

It is clear from the picture that the new graph has one less crossover point, and one can easily verify that X is satisfiable if and only if $[a_1 \Leftrightarrow a]$ and $[b_1 \Leftrightarrow b]$.

The algorithm repeats the above replacement at each crossover point, starting at lower right and moving up and left, using new auxiliary variables each time, until the graph is finally planar.

At each stage of the algorithm, only a constant amount of work is done, and there are no more than $9m^2$ stages.

Now we draw in A_3 without disturbing the planarity of the graph. Since all of the new variables are in the same existence block, we are free to order them arbitrarily.

Taking another look at our planar crossover box, we notice that there is a simple path linking all of its variables (i.e., the dark lines in Fig. 5). We use this fact to show how to connect all of the new variables together, as in Fig. 6.

Notice that we have used extra boxes to allow arcs in A_3 to cross A_1 arcs as necessary (see Fig. 6). This can add no more than $9m^2$ new boxes, and the algorithm is thus clearly polynomial. Q.E.D.

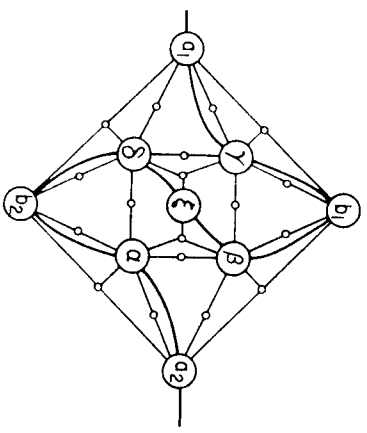

FIG. 5

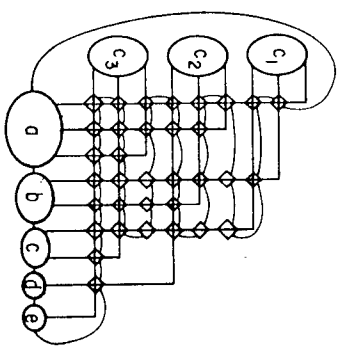

FIG. 6

DEFINITION. Planar 3SAT(P3SAT) is 3SAT restricted to formulae B such that $G(B)$ is planar.

THEOREM 2. P3SAT is NP-complete.

As remarked above, this is a corollary of Theorem 1. A word about the arcs in A_3 : They are irrelevant for the reduction to node cover, and, for the reductions to Hamiltonian line, geometric connected dominating set and geography, the arc $[u_m, t_j]$ will have to be deleted, so as to make the path taken by the A arcs a Hamiltonian line rather than a Hamiltonian circuit.

4. Planar node cover.

DEFINITION. A node cover C of a graph G is a subset of the nodes of G with the property that every arc of G is incident to a node in D .

THEOREM 3. Node cover is NP-complete even when restricted to the class of planar graphs.

Proof. We present Garey, Johnson and Stockmeyer's proof [5] that node cover is NP-complete, and then show how to strengthen it for the planar case.

Given a boolean formula B in 3CNF with m clauses in n variables, form the following node cover problem NCB $_B$, which will have a node cover of size $5m$ if and only if B is satisfiable.

Each clause is represented by a triangle, and each variable is represented by a simple cycle of length $2m_i$. Even numbered nodes in the cycle represent negative instances of the variable, and odd numbered nodes represent unnegated instances.

Arcs go between triangles and cycles whenever the variable represented by the cycle occurs in the clause represented by the triangle. Each node in a triangle is used only once (see Fig. 7).

At least half the nodes from each cycle must be in any node cover, and this minimum can be achieved only if every other node is chosen. At least two nodes from each triangle must be in any node cover. The rest of the proof involves showing that these two local minima are achieved, then B is satisfiable.

Note that the choice of which clause node to attach to which node in the cycle is arbitrary, and that this choice determines a cyclic ordering of clauses around each variable and of variables around each clause.

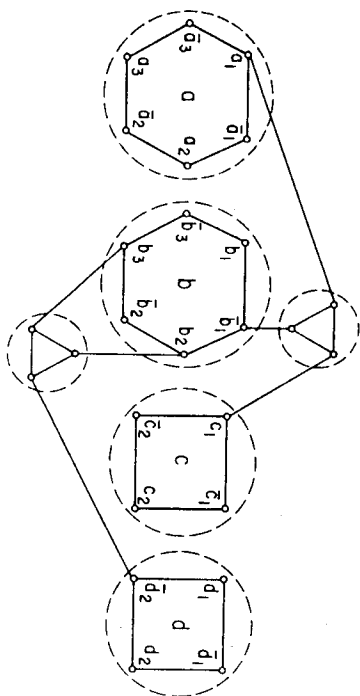

Example : $B = (a + \bar{b} + c)(b + b + \bar{d})$

FIG. 7

If each variable structure and each triangle is viewed as a single macro node, as the dotted lines indicate, then the resulting graph is simply $G(B)$. There is a choice of cyclic orderings of clauses around variables and variables around clauses for which $NC(B)$ is planar if and only if $G(B)$ is planar. Since any (polynomial) planarity algorithm can find such an ordering if it exists, Theorem 2 applies and the theorem is proved. Q.E.D.

5. Planar directed Hamiltonian circuits.

THEOREM 4. Planar directed Hamiltonian circuit is NP-complete [6].

Proof. (This proof is due to Michael Sipser.) We show how to construct $H(B)$, a graph that has a Hamiltonian circuit if and only if B is satisfiable. Variables are represented by ladders, as shown in Fig. 8. Choosing the variable true will mean

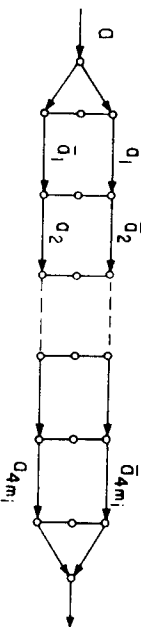
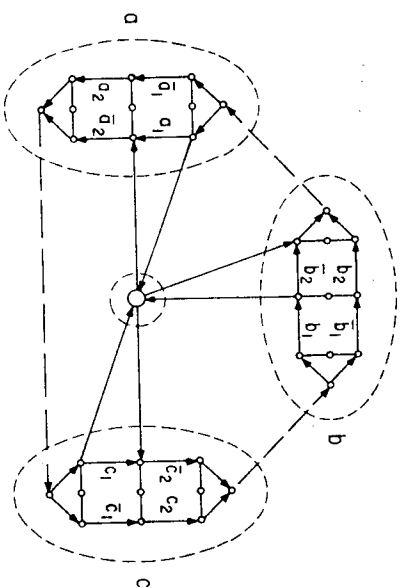

FIG. 8

traversing the nodes in the ladder in a zig-zag starting at the top; choosing the variable false will mean starting at the bottom. The length of the ladder will be the number of (undirected) cross rungs, and the ladder for the variable v_i will be $4m_i$ long. ($4m_i$ is long enough so that we can leave gaps between sections of the ladder linked to two different clauses.)

Clauses are simply single nodes. They are connected to ladders as in the example shown in Fig. 9.

To complete the construction, the ladders are linked together in a global Hamiltonian circuit (drawn in long dashes).



$B = (a + \bar{b} + c)$

FIG. 9

Claim. If B is satisfiable, the Hamiltonian circuit in $H(B)$ zigzags the appropriate way in each ladder, and traverses each clause node by interrupting the path in the ladder to jump up and back down to the ladder, as in Fig. 10. Note that the choice of which variable to use in satisfying the clause is arbitrary for clauses with more than one true literal.

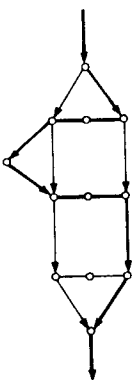

FIG. 10

The converse is nearly as simple. If $H(B)$ has a Hamiltonian circuit, we now show that it cannot leave a ladder in the middle via a clause, but instead must continue down until the end of the ladder.

Suppose then that $H(B)$ has a Hamiltonian circuit which misbehaves, i.e., jumps from one variable to another via a clause, as in Fig. 11.

It should be clear that each Hamiltonian circuit in $H(B)$ looks right, i.e., that it zigzags easily from the fact that each Hamiltonian circuit in $H(B)$ looks right, i.e., that it zigzags correctly through variables and returns immediately to the ladder it came from after traversing a clause node.

We can now invoke Theorem 2 in the same way we did in the previous section, and the theorem is proved. Q.E.D.

COROLLARY. Planar directed Hamiltonian line is NP-complete.

Proof. Just delete one are from the global circuit, e.g., the one representing $\{v_1, \dots, v_m\}$ from A_2 . \square

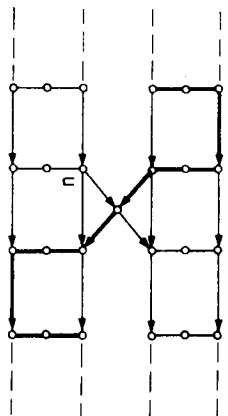

Fig. 11

COROLLARY. *A more involved case analysis shows that the directions on the arcs in the construction are unnecessary, and this gives us the NP-completeness of planar undirected Hamiltonian circuit and line. These were first proved in [6].*

The next two proofs are less straightforward than the previous two in that we can not simply demonstrate a reduction from 3SAT and then invoke Theorem 7. This leads us to a choice of where to do the extra tinkering necessary. One can either invent more complicated reductions and use more involved proofs of the correctness of the reduction, or try to massage boolean formulae into forms more easily reducible to the problem at hand. The strategy followed in this paper is to do as much of the work as possible with boolean formulae so as to have to prove as little as possible about unfamiliar, uncooperative combinatorial structures.

6. Geometric connected dominating set.

Problem. Given a set of cities in the plane, each of which has a receiver operational with a radius of d , can k transmitters be apportioned so that a message originating at one transmitter can be relayed to every city?

The above problem is a version of the dominating set problem, and was posed by Phil Spira in connection with packet radio network design.

DEFINITION. A dominating set of nodes in a graph is a subset of the nodes in the graph with the property that every node not in the set is adjacent to a node that is in the set.

DEFINITION. The connected dominating set problem (CD): Given a graph G and an integer k , is there a connected subset of size k that is a dominating set?

DEFINITION. The geometric connected dominating problem (GCD) is CD when the nodes are a set of points in the Euclidean plane, and an arc is drawn between all pairs of points no greater than distance 1 apart.

THEOREM 5. GCD is NP-complete.
Proof. R , as usual, is a boolean formula in 3CNF with m clauses and n variables. We wish to construct an equivalent GCD problem, GCD(B).

Our method of presentation will be as follows: First, we present the structures we would like to use in the proof. Then, according to the strategy outlined earlier, we formulate a corollary to Theorem 1 which facilitates the reduction, and last we show the entire construction and prove its correctness.

We want to represent each variable by a set of points in the plane of the form shown in Fig. 12. Choosing a variable true corresponds to putting all the nodes in the top row into the connected dominating set; eds; false puts the bottom row in. The square nodes force at least one of the two nodes adjacent to it into any eds. The structure is long



Fig. 12

enough to prevent unwanted interactions between nearby clauses, just as in the Hamiltonian circuit construction.

The variables will all be linked together by a line we call a ground (see Fig. 13).

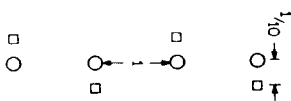

Fig. 13

The ground will follow the path taken by the A_2 arcs from $G(B)$. Figure 14 is a detailed view of the ground passing through a variable. Notice that we have had to move the square forces outside the variable in the two parts near the ground, since otherwise the forces would be near the ground, and would not force at least of the two nearby nodes from the variable into the eds.

Each clause is represented by the kind of structure shown in Fig. 15. If the j th clause is $(a + \bar{b} + c)$, then one circled node will be within 1 of a top node representing a one will be near a bottom node in the structure representing b , and one will be near a top node in the structure representing c .

Notice that the uncircled round nodes are forced into any eds by the square nodes nearby. In general, we will refer to a node which is forced into any eds by a nearby square node as *forced*.

At this point the reader should notice a glaring discrepancy between variable nodes as defined in § 3 and the variable structure we intend to use here to represent them. The latter are bipolar, by which we mean that all clauses containing a positive instance of a variable must be positioned near the top of the variable, and all clauses containing a negative instance of the variable must be positioned near the bottom. We imposed no

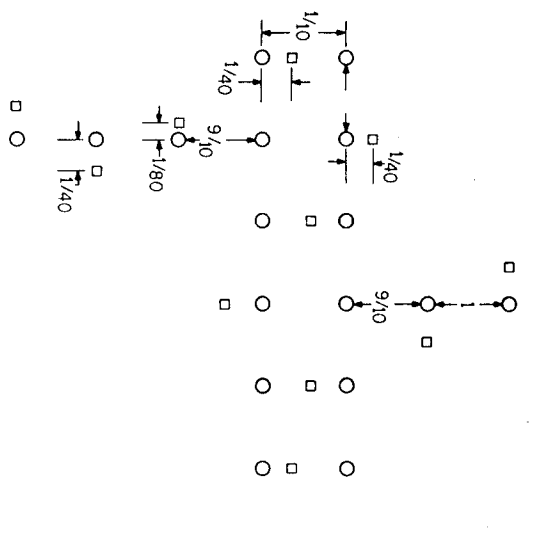

FIG. 14

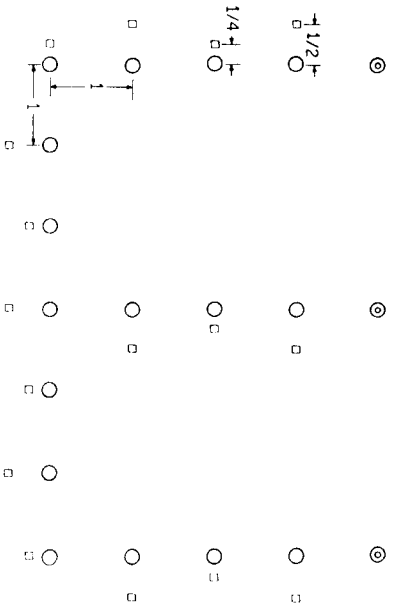

FIG. 15

such restriction in our definition of planar formulae. We do so now, and prove the resulting problem is still NP-complete.

LEMMA 1. Planar satisfiability is still NP-complete even when, at every variable node, all the arcs representing positive instances of the variable are incident to one side of the node and all the arcs representing negative instances are incident to the other side. (Equivalently, we can have separate nodes for positive and negative literals, and add an arc between the (now) two nodes representing a single variable.)

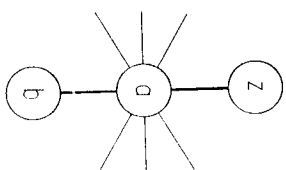

FIG. 16

Proof. Take the planar embedding of the graph of the formula (see Fig. 16), and replace each variable a with a cycle of m_a variables a_1 , together with clauses $(a_1 + a_2)$ for variables a_1 and a_2 such that ka_1 follows a_1 in a clockwise traversal of the cycle. (Notice in Fig. 17 that the ordering of variables in the cycle is different from the ordering followed by the A_2 arcs.) These clauses have the effect of forcing $a_1 \Leftrightarrow a_2$ for all a_1 and a_2 in the cycle. A_2 arcs are embedded as in Fig. 17.

Now, back to the problem at hand. Let:

$NV = \frac{1}{2}$ the number of nodes in all the variable structures;

$NC =$ the number of forced nodes in all the clause structures;

$NG =$ the number of forced nodes in the ground.

Let $k = NV + NC + NG + m$.

Claim. $GCD(B)$ has a connected dominating set of size k if and only if B is satisfiable.

\Leftarrow Choose top and bottom rows in variables according to whether the variable is true or false in a given satisfying instance of B . Pick one circled node in each clause that lies within 1 of a variable already chosen. Pick all the forced nodes in each clause and in the ground.

\Rightarrow Let $GCD(B)$ have a connected dominating set of size k . We show that this set must look right. Call a node live if it is in the eds. Suppose some variable switches from true to false at least once. Then suppose we want to find a path from a live node in the left half of the variable to the right half. Since the ground follows the route taken by A_2 arcs, and is therefore a Hamiltonian line through the variables, the path we are looking for must go through at least one clause c_i . This means some clause has two live circled nodes, since otherwise clauses are cuts de sac. Since our threshold, k is a sum of local

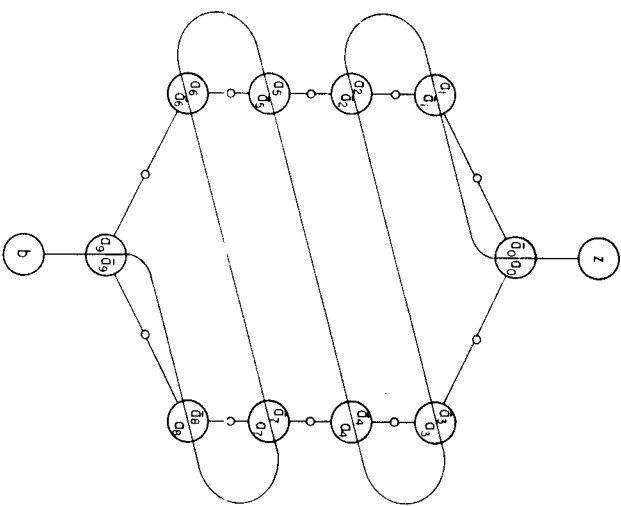

Fig. 17

minima, there is no slack anywhere to make up for the extra live node in c_i . So every variable has either the entire top row live, or the entire bottom row live.

The rest of the proof involves showing that the entire graph can be embedded in the plane in such a way that nodes are at rational points whose precision is bounded by a polynomial in the size of the number of points. This demonstration is straightforward, and we omit it. QED.

7. Generalized geography.

DEFINITION. Generalized geography (GG) is a game played by two players on the nodes of a directed graph. Play begins when the first player puts a marker on a distinguished node. In subsequent turns, players alternately place a marker on any unmarked node q_i such that there is a directed arc from the last node played to q_i . The first player who cannot move loses.

This is a generalization of a commonly played game in which players must name a place not yet mentioned in the game, and whose first letter is the same as the last letter of the last place named. The first player to be stumped loses. This instance of geography would be modelled by a graph with as many nodes as there are places. Directed arcs would go from a node u_i to all those nodes whose first letters are the same as u_i 's last letter.

THEOREM 6. GG is P-space complete [11].

Proof. We are given a formula $B \in Q3CNF$, $B = Q_1 v_{1,1}, Q_2 v_{2,2}, \dots, Q_n v_{n,n}$, $F(v_{1,1}, v_{2,2}, \dots, v_{n,n})$. Assume without loss of generality, that $Q_1 = V$, $Q_n = \exists$, and that $Q_i \neq Q_{i+1}$ for $1 \leq i \leq n$. Construct the graph $GG(B)$, which is shown in Fig. 18.

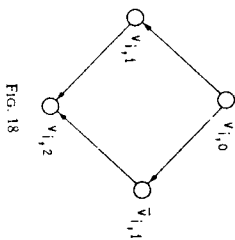
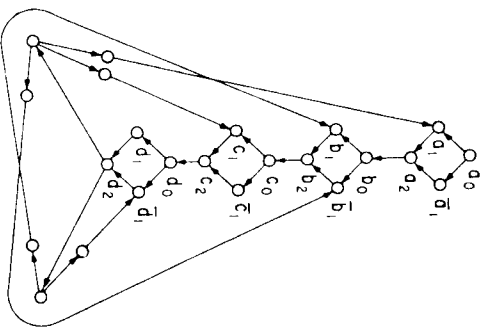

Fig. 18

Each variable, v_i , is represented by a diamond structure, and each clause, c_i , is represented by a single node. In addition, we have arcs $(v_i, v_{i+1,0})$ for $1 \leq i < n$, $(v_{n,2}, c_i)$ for $1 \leq i \leq m$, and paths of length two going from c_i to $v_{i,1}$ for v_i in c_i , and from c_i to \bar{v}_i for \bar{v}_i in c_i . $v_{1,0}$ is the distinguished node (see Fig. 19).



Example:

$$\exists a \forall b \exists c \forall d (a + \bar{b} + c)(b + \bar{d})$$

Fig. 19

Play proceeds as follows: One player chooses which path to take through V -diamonds (i.e., diamonds representing universally quantified variables), and the other player chooses which path to take through \exists -diamonds. After all diamonds have been traversed, the V -player chooses a clause, and the \exists -player then chooses a variable from that clause. \exists then wins immediately if the chosen variable satisfies the clause; otherwise, V wins on the next move. Assuming both players play optimally, it follows easily that \exists wins if and only if B is true (we leave the details to the reader).

Planar generalized geography.

THEOREM 6. *Generalized geography is P-space complete even when played only on planar graphs.*

Proof. There is a problem which prevents us from merely invoking Lemma 1 to give us the proof, namely, the set of arcs, $\{(i_n, c_j) \mid i \leq j \leq m\}$.

To solve this problem, we make the following observation: There is no need to wait until all variables have had their truth values chosen before allowing the V -player to test the truth of a clause; in fact, each clause can be tested as soon as its last variable has had its value fixed. Moreover, it is only necessary to allow testing of clauses not satisfied by their last chosen variable.

In order to implement this idea, we need variable structures which are large enough so that every clause has a different node of attachment to the structure. Moreover, this node must be one at which V has the choice of direction. Since each variable occurs in at most three clauses (by Lemma 1), the structure in Fig. 20 suffices.

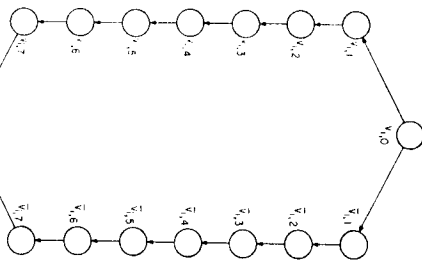

Fig. 20

The clause construction is now as in the following example. Let $c_i = (a + \bar{b} + \bar{d})$, where d is the variable with the highest index of the three (i.e., is quantified last). The corresponding arcs in $GC(B)$ are a path of length two going from c_i to an unused node from the set $\{a_1, \dots, a_7\}$; a path of length two going from c_i to an unused node from the

set $\{b_1, \dots, b_7\}$ and (d_2, c_1) , (d_4, c_1) or (d_6, c_1) if d is a V -variable, else (d_1, c_1) , (d_3, c_1) or $V(d_5, c_1)$. Notice that if d is chosen true, there is no way for the V player to test c_i . In fact, it would not be in V 's interest to do so.

At this point, we invoke Lemma 1 and the theorem is proved. Q.E.D.

8. Conclusion. We have seen how one planar completeness result easily produces others through the use of transformations under which planarity is invariant. We suspect that it is possible to obtain easy NP-completeness proofs for the planar version of Steiner tree, triangulation existence and minimum weight triangulation. We suggest that it may be profitable to use other artificial sets (e.g., planar exact 3-cover, appropriately defined) to obtain other sets of uniform and easy proofs.

Planar generalized geography has been used to prove P-space completeness of appropriately generalized versions of chess, checkers, go, and hex [13], [3], [8], [10]. A simpler proof of the P-space completeness of generated geography was presented in [7] but the proof in this paper is the original one, and we have included it here more as a justification for planar formulae than for its own sake.

Acknowledgments. I wish to thank Shimon Even, Faith Fich, Michael Garey, Michael Cutsky, David Johnson, Richard Karp, Eugene Lawler and Michael Sipser for their help with this paper. Thanks also go to the Weizmann Institute of Science and the Hebrew University in Jerusalem for allowing me the use of their facilities while writing the paper.

REFERENCES

- [1] A. V. AHO, J. E. HORROCKS AND J. D. ULLMAN, *The Design and Analysis of Computer Algorithms*, Addison-Wesley, Reading, Mass., 1974.
- [2] S. A. COOK, *The complexity of theorem-proving procedures*, Proc. Third ACM Symposium on Theory of Computing, 1971, pp. 131-158.
- [3] A. S. FRANKEL, M. R. GAREY, D. S. JOHNSON, T. SCHAFFER AND Y. YESHA, *The complexity of checkers on an $N \times N$ board*, Proc. 19th IEEE Symposium on Foundations of Computer Science, 1978, pp. 55-64.
- [4] M. R. GAREY AND D. S. JOHNSON, *The rectilinear Steiner tree is NP-complete*, SIAM J. Appl. Math. 32 (1977), pp. 826-834.
- [5] M. R. GAREY, D. S. JOHNSON AND L. STOCKMEYER, *Some simplified NP-complete problems*, Proc. 5th ACM Symposium on Theory of Computing, 1974, pp. 47-63.
- [6] M. R. GAREY, D. S. JOHNSON AND R. E. TARJAN, *The planar Hamiltonian circuit problem*, NP-complete, this Journal 5 (1976), pp. 704-714.
- [7] R. M. KARP, *Reducibility among combinatorial problems*, Complexity of Computer Computations, R. E. Miller and J. W. Thatcher, eds., Plenum Press, New York, 1972, pp. 85-104.
- [8] D. LICHTENSTEIN AND M. SIPSER, *GO is polynomial space hard*, J. Assoc. Comput. Mach., 27 (1980), pp. 393-401.
- [9] A. R. MEYER AND L. J. STOCKMEYER, *Word problems requiring exponential time*, Proc. 5th ACM Symposium on Theory of Computing, 1973, pp. 1-9.
- [10] S. REISCH, *Hex für PSPACE*, *colloquium private communication*.
- [11] T. J. SCHAFFER, *On the complexity of some two-person perfect information games*, J. Comput. System Sci., 16 (1978), pp. 185-225.
- [12] L. STOCKMEYER, *Planar 3-colorability is polynomial complete*, SIGACT News 5 (1973), pp. 19-22.
- [13] J. A. STORFFER, *A note on the complexity of chess*, Proc. 1979 Conference on Information Sciences at Systems, Dept. Electrical Engineering, The Johns Hopkins University, Baltimore, Maryland, 1979, pp. 160-166.