

A Counterexample to the Generalized Baues Conjecture

Jörg Rambau*

Günter M. Ziegler**

Fachbereich Mathematik, MA 6-1
Technische Universität Berlin
Straße des 17. Juni 136
D-10623 Berlin, Germany

`rambau@math.tu-berlin.de`
`ziegler@math.tu-berlin.de`

February 3, 1995

Abstract

Associated with every projection $\pi : P \rightarrow \pi(P)$ of a polytope P one has a partially ordered set of all “locally coherent strings”: the families of proper faces of P that project to valid subdivisions of $\pi(P)$, partially ordered by the natural inclusion relation.

The “Generalized Baues Conjecture” posed by Billera, Kapranov & Sturmfels [4] asked whether this partially ordered set always has the homotopy type of a sphere of dimension $\dim(P) - \dim(\pi(P)) - 1$. We show that this is true in the cases when $\dim(\pi(P)) = 1$ (see [4]) and when $\dim(P) - \dim(\pi(P)) \leq 2$, but fails otherwise.

*graduate school “Algorithmische Diskrete Mathematik”, supported by the Deutsche Forschungsgemeinschaft (DFG), grant We 1265/2-1

**supported by a “Gerhard-Hess-Forschungsförderpreis” of the Deutsche Forschungsgemeinschaft (DFG)

1 Introduction

In this paper we study the poset $\omega(P, \pi)$ of all “locally coherent strings” (defined below) associated with a projection of a convex polytope. In particular, we prove a new special case of the Generalized Baues Conjecture about the homotopy type of this poset, and disprove the Conjecture by explicit counterexamples in the general case.

The investigation of the posets $\omega(P, \pi)$ is motivated by problems that are concerned with the global (topological) structure of a restricted set of subdivisions of a fixed compact space. Such problems appear in very different frameworks, among them

- model theory of loop spaces (see Adams [1] and Baues [2]),
- spaces of triangulations of manifolds (see Nabutovsky [13] for recent work),
- triangulations of point configurations and local transforms (see Joe [9, 10]),
- extension spaces of oriented matroids (see Sturmfels & Ziegler [15]), and
- finite models for the finite-dimensional Grassmannian (see MacPherson [11] and Mnëv & Ziegler [12]).

The Generalized Baues Conjecture, whose precise setting we now introduce, directly applies to several of the situations we have just listed, and provides a prototypical model for the others.

Let $\pi : P \rightarrow \pi(P)$ be a projection of polytopes. Here we assume that P is a d -polytope in \mathbb{R}^d , $\pi(P)$ is a d' -polytope in $\mathbb{R}^{d'}$, and $\pi : \mathbb{R}^d \rightarrow \mathbb{R}^{d'}$ is an affine map. If π maps more than one vertex of P to a single point in $\pi(P)$ we call π *degenerate*, while π is *weakly non-degenerate* otherwise. If each affine dependence between projections $\pi(v_1), \pi(v_2), \dots, \pi(v_k)$ of vertices v_1, \dots, v_k in $\pi(P)$ is induced by an affine dependence between the vertices v_1, \dots, v_k in P , then we call π (*strongly*) *non-degenerate*. The main objects of this paper are the following.

Definition 1.1 A *locally π -coherent string* — or a *locally coherent string* for short — is a collection \mathcal{F} of nontrivial faces of P (that is, faces different from P and from \emptyset), such that

- $\{ \pi(F) \mid F \in \mathcal{F} \}$ is a polytopal subdivision of $\pi(P)$ without repetitions, that is, the sets $\pi(F)$ are distinct polytopes which form a polytopal complex with union $\pi(P)$, and
- $\pi(F) \subseteq \pi(F')$ implies $F = F' \cap \pi^{-1}(\pi(F))$, for $F, F' \in \mathcal{F}$.

The finite set of all locally π -coherent strings is partially ordered by

$$\mathcal{F} \leq \mathcal{F}' \quad : \iff \quad \bigcup \mathcal{F} \subseteq \bigcup \mathcal{F}'.$$

The resulting partially ordered set (poset) of locally π -coherent strings is denoted by $\omega(P, \pi)$. A string $\mathcal{F} \in \omega(P, \pi)$ is called

- *tight* if $\dim(\pi(F)) = \dim(F)$ for all $F \in \mathcal{F}$,
- *globally π -coherent* — or *coherent* for short — if there exists a $\psi \in (\mathbb{R}^d)^* \setminus \{0\}$ such that π can be factorized to

$$\pi : P \xrightarrow{(\pi, \psi)} \{ (\pi(x), \psi(x)) \mid x \in P \} \xrightarrow{pr_1} \pi(P),$$

and $(\pi, \psi)(\mathcal{F})$ is locally pr_1 -coherent. The subposet of all coherent strings is written as $\omega_{\text{coh}}(P, \pi) \subseteq \omega(P, \pi)$. \square

Definition 1.1 is equivalent to the definition of the set of all π -induced subdivisions of $\pi(P)$, denoted “ $\omega(P, \pi(P))$,” in the paper of Billera, Kapranov & Sturmfels [4]. Since in general there may be many different locally π -coherent strings that determine the same polytopal subdivision of $\pi(P)$, we emphasize by our notation that one is dealing with objects in P rather than with subdivisions of $\pi(P)$.

Billera & Sturmfels [5], [16, Thm. 9.6] showed that the subposet $\omega_{\text{coh}}(P, \pi)$ is isomorphic to the poset of proper faces of the *fiber polytope* $\Sigma(P, \pi)$ of the projection π , a convex polytope of dimension $d - d'$. Thus the order complex (simplicial complex of chains, see Björner [7]) of $\omega_{\text{coh}}(P, \pi)$ is homeomorphic to a sphere of dimension $d - d' - 1$. In general, the poset $\omega(P, \pi)$ is strictly larger than $\omega_{\text{coh}}(P, \pi)$, and not homeomorphic to a sphere. (See e. g. [16, Section 9.1].) However, in 1980 Baues conjectured in his work on a model theorem for loop spaces [2] (in somewhat different language) that for $d' = 1$ the poset $\omega(P, \pi)$ of all locally coherent strings is homotopy equivalent to the sphere S^{d-2} . In 1991, Billera, Kapranov & Sturmfels extended this to the following conjecture.

Conjecture 1.2 (“Generalized Baues Conjecture”) [4] [14, Sect. 5]

For every projection of polytopes $\pi : P \rightarrow \pi(P)$, the poset $\omega(P, \pi)$ of all locally π -coherent strings is homotopy equivalent to the $(d - d' - 1)$ -sphere.

Even stronger, $\omega_{\text{coh}}(P, \pi)$ is a retract of $\omega(P, \pi)$: the inclusion map

$$\omega_{\text{coh}}(P, \pi) \hookrightarrow \omega(P, \pi)$$

is a homotopy equivalence. \square

Even for projections of reasonably small and simple polytopes, the poset of all locally coherent strings can be large and complicated (see e.g. [16, p. 297]). Up to now the main positive result, motivating the Generalized Baues Conjecture, was the following theorem, which settled the original conjecture by Baues [2].

Theorem 1.3 (Billera, Kapranov & Sturmfels [4])

The Generalized Baues Conjecture holds for $d' \leq 1$. □

Actually, the proof of Theorem 1.3 in [4] is formulated only for the case where the projection is non-degenerate. However, the proof can be extended to the general case without greater difficulty. We refer to Björner [6], Billera & Sturmfels [5], Sturmfels [14], Sturmfels & Ziegler [15], and Mnëv & Ziegler [12] for related discussions and other partial results. Our main positive result is the following special case.

Theorem 1.4

The Generalized Baues Conjecture holds for $d - d' \leq 2$. □

After preliminary work on the structure of locally coherent strings (including a characterization theorem in terms of functions on the chamber complex of the projection) in Section 2, we will prove Theorem 1.4 in Section 3.

Theorem 1.5

The Generalized Baues Conjecture is false in general for $d' \geq 2$ and $d - d' \geq 3$. □

In Section 4 we show a construction for polytope projections that have an isolated element in the poset of all locally coherent strings, thus proving Theorem 1.5. In order to provide more geometric/combinatorial intuition for “what goes wrong here,” we present explicit coordinates for two counterexamples in Section 5, together with simple, independent proofs that these polytope projections violate the Generalized Baues Conjecture. These proofs depend on “hands-on” knowledge of the face lattices of the polytopes, as can be obtained from Fourier-Motzkin elimination (or any similar convex hull algorithm).

The first example is one special instance of the counterexample construction in Section 4. It is an extremely degenerate projection $\pi^{\text{deg}} : P^{\text{deg}} \rightarrow \pi(P^{\text{deg}}) =: Q^{\text{deg}}$, where P^{deg} is a 5-polytope with 10 vertices and 36 facets and Q^{deg} is a triangle. Each vertex of P^{deg} is projected by π^{deg} either to a vertex or to the center of the triangle Q^{deg} . In this case $\omega(P^{\text{deg}}, \pi^{\text{deg}})$ has an isolated element.

The second example — obtained by perturbation of the vertices of the first — is a strongly non-degenerate projection $\pi : P \rightarrow \pi(P) =: Q$, where P is a 2-neighborly, simplicial 5-polytope with 10 vertices and 42(!) facets, and Q is a hexagon. Here $\omega(P, \pi)$ is disconnected: the locally coherent strings of one connected component all have the face lattices of three special 2-faces of P in common.

By Theorems 1.3 and 1.4 these counterexamples have both minimal dimension and codimension. They easily imply that the Generalized Baues Conjecture also fails in any higher dimension and codimension.

2 Functions on the chamber complex

In this section we point out two crucial facts. The first one describes a basic property of the chamber complex of a polytope projection, the second one is a “local coherence condition” in terms of the normal fans of the fibers of the projection.

Given any linear or affine function ψ on a space that contains the polytope P , we use P^ψ to denote the set of all points in P on which ψ is maximal. This set P^ψ is a *face* of P , and all nonempty faces of P have this form ($\psi = 0$ corresponds to P itself). We use $L(P)$ to denote the *face lattice* of P : the set of all faces of $P \subseteq \mathbb{R}^d$, partially ordered by inclusion. This includes the *trivial faces* \emptyset and P .

For a polytope projection $\pi : P \rightarrow \pi(P) =: Q$ as above, the *chamber complex* Γ is the set of intersections of all images of faces of P that contain a given point in Q , that is,

$$\Gamma := \{ \sigma(q) \mid q \in Q \},$$

where

$$\sigma(q) := \bigcap \{ \pi(F) \mid q \in \pi(F), F \in L(P) \}$$

is the *chamber of* $q \in Q$. (It can be shown that Γ is a polytopal complex subdividing Q . The chamber complex Γ is the common refinement of all π -coherent subdivisions of Q , and therefore shellable.)

There is no loss of generality if we assume from now on that the projection map $\pi : \mathbb{R}^d \rightarrow \mathbb{R}^{d'}$ is the restriction to the last d' coordinates. For any $q \in Q$ the *fiber* of q is the polytope

$$P_q := \{ x \in \mathbb{R}^{d-d'} \mid (x, q) \in P \}.$$

Thus we consider the fibers as full-dimensional polytopes P_q in the (fixed) vector space $\mathbb{R}^{d-d'}$. Whenever we need to interpret a fiber as a subset of \mathbb{R}^d we write $i_q(P_q)$, where $i_q(x) := (x, q) \in \mathbb{R}^d$. The (surjective) map $i_q^* : (\mathbb{R}^d)^* \rightarrow (\mathbb{R}^{d-d'})^*$ is as usual defined by $i_q^*(\alpha)(x) := \alpha(i_q(x)) = \alpha(x, q)$.

The nonempty faces of the fibers P_q can be represented in the form P_q^ψ , where ψ is a linear functional $\psi \in (\mathbb{R}^{d-d'})^*$. Now if P_q^ψ is any nonempty face of a fiber P_q , then we use $[\psi]$ to denote the (closed, polyhedral) cone in $(\mathbb{R}^{d-d'})^*$ of all linear functions that are maximal on the face P_q^ψ of P_q . This set $[\psi]$ is the *normal cone* of the face P_q^ψ . If q' is another point that lies in the relative interior of the same chamber of the chamber complex as p , then the normal cones of the face P_q^ψ of P_q and $P_{q'}^\psi$ of $P_{q'}$ coincide (That is, the fibers P_q and $P_{q'}$ are *normally equivalent*, see e. g. Billera & Sturmfels [5].) Thus we can use the notation $[\psi]_\sigma$ for the normal cone of the face that ψ defines in the fiber, called the *normal cone over σ induced by ψ* . Moreover, let $N(\sigma)$ denote the fan consisting of all normal cones over σ , the *normal fan over σ* (that is, the normal fan of the fiber over a point in the relative interior of σ).

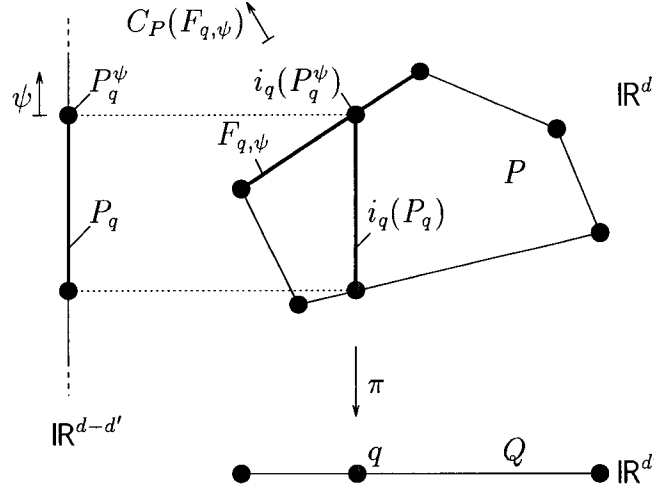

Figure 1: The face $F_{q,\psi}$ induced by $\psi \in (\mathbb{R}^{d-d'})^*$.

For each face P_q^ψ of a fiber P_q there is a unique minimal face of P that contains P_q^ψ (the intersection of all faces that contain P_q^ψ). We use $F_{q,\psi}$ to denote this face of P corresponding to the face P_q^ψ of P_q . For its normal cone in $(\mathbb{R}^d)^*$ we use the notation $C_P(F_{q,\psi})$. Figure 1 depicts the situation for $d = 2$ and $d' = 1$.

The following Lemma collects the elementary basic facts.

Lemma 2.1 (Basic facts) *The faces of the polytope P , of the fibers P_q , and the chambers $\sigma \in \Gamma$, are related as follows.*

(i) *The chamber of $q \in Q$ is given by*

$$\sigma(q) = \bigcap_{\psi \in (\mathbb{R}^{d-d'})^*} \pi(F_{q,\psi}).$$

(ii) *For all $q \in Q$ and $\psi, \psi' \in (\mathbb{R}^{d-d'})^*$*

$$P_q^\psi < P_q^{\psi'} \iff F_{q,\psi} < F_{q,\psi'}$$

(iii) *For all $q, q' \in Q$ and $\psi \in (\mathbb{R}^{d-d'})^*$*

$$\begin{aligned} q' \in \text{relint } \pi(F_{q,\psi}) &\implies F_{q',\psi} = F_{q,\psi}, \\ q' \in \partial \pi(F_{q,\psi}) &\implies F_{q',\psi} \subset F_{q,\psi}, \\ \pi(F_{q',\psi}) \subset \pi(F_{q,\psi}) &\iff F_{q',\psi} \subset F_{q,\psi}, \\ \pi(F_{q_1,\psi} \cap \dots \cap F_{q_k,\psi}) &= \pi(F_{q_1,\psi}) \cap \dots \cap \pi(F_{q_k,\psi}). \end{aligned}$$

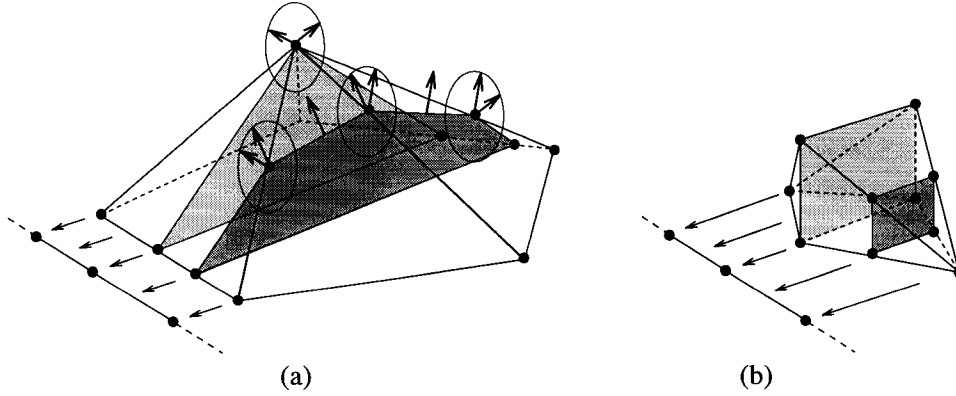

Figure 2: The normal fan relation.

(iv) Let $q' \in \sigma(q)$, $q \in Q$, $x \in P_q^\psi$, $x' \in P_{q'}^\psi$ and $\alpha \in C_P(F_{q,\psi})$. Then

$$i_{q'}^*(\alpha)(x') = i_q^*(\alpha)(x).$$

(v) The normal cone $C_P(F_{q,\psi})$ of $F_{q,\psi}$ in $(\mathbb{R}^d)^*$ is mapped by i_q^* onto the normal cone of P_q^ψ in $(\mathbb{R}^{d-d'})^*$.

(vi) For each face F of P there exist $q \in Q$ and $\psi \in (\mathbb{R}^{d-d'})^*$ such that

$$F = F_{q,\psi}.$$

□

As a corollary of (iii) we get that if ψ is fixed, then the face $F_{q,\psi}$ does not change if q moves in the relative interior of the chamber $\sigma(q)$. Hence with each chamber σ and each functional ψ we can associate a well-defined face of P , via

$$F_{\sigma,\psi} := F_{q,\psi}, \quad q \in \text{relint}(\sigma).$$

The following “normal fan relation” of the chamber was used in the special case $d' = 1$ by Billera, Kapranov & Sturmfels [4] in their proof of the Baues Conjecture. Here we state its general validity.

Lemma 2.2 *If τ is a face of σ in the chamber complex Γ , then for each $\psi \in (\mathbb{R}^{d-d'})^*$ the normal cone over τ defined by ψ is contained in the corresponding normal cone over σ :*

$$\tau < \sigma \in \Gamma \implies [\psi]_\sigma \subseteq [\psi]_\tau.$$

Hence, the normal fan over σ is a refinement of the normal fan over τ :

$$N(\sigma) \leq N(\tau).$$

Proof: Let $\phi = i_q^*(\alpha)$ be a linear functional on $(\mathbb{R}^d)^*$ in $[\psi]_\sigma$ with $q \in \text{relint}(\sigma)$ and some α in the normal cone $C_P(F_{\sigma,\psi})$ of $F_{\sigma,\psi}$ in P by Lemma 2.1(v). Then

$$\phi = i_q^*(\alpha) \in i_q^*(C_P(F_{\sigma,\psi})).$$

But this is contained in $i_{q'}^*(C_P(F_{\sigma,\psi}))$ for each $q' \in \sigma$ (Lemma 2.1(iv)), especially for $q' \in \tau$.

We know from Lemma 2.1(iii) that if τ is a face of σ then $F_{\tau,\psi}$ is a (not necessarily proper) face of $F_{\sigma,\psi}$ for all $\psi \in (\mathbb{R}^{d-d'})^*$. Hence, again from Lemma 2.1(v) we derive

$$i_{q'}^*(C_P(F_{\sigma,\psi})) \subseteq i_{q'}^*(C_P(F_{\tau,\psi})) = [\psi]_\tau,$$

which completes the proof. \square

Remark 2.3 In general we cannot expect a strict refinement (see Figure 2), because the map $i_{q'}$ does not preserve strict inclusions if the projection is degenerate. But if we restrict ourselves to non-degenerate projections then the cone inclusion has to be proper for at least one $\psi \in (\mathbb{R}^{d-d'})^*$, and therefore the fan refinement is strict. \square

The following proposition describes the relations between the fibers over adjacent chambers even metrically.

Proposition 2.4 *Let $\sigma \in \Gamma$ be a chamber with vertices v_1, \dots, v_k and*

$$q = \sum_{i=1}^k \lambda_i v_i$$

with $\lambda_i \geq 0$ and $\sum_{i=1}^k \lambda_i = 1$.

Then P_q is the Minkowski sum of the fibers over the vertices of σ , scaled as in the representation of q in σ ,

$$P_q = \sum_{i=1}^k \lambda_i P_{v_i}.$$

Proof: Consider the polytope projection

$$\pi_\sigma : P_\sigma := \pi^{-1}(\sigma) \rightarrow \sigma.$$

in this very special case the fiber each vertex v_i of σ is the convex hull of vertices $v_{i,1}, \dots, v_{i,l(i)}$ of P_σ and these are the only vertices of P_σ . This yields the claim after a straightforward computation. \square

Corollary 2.5 *The normal fan over the relative interior of a chamber $\sigma \in \Gamma$ is exactly the common refinement of the normal fans over the faces of σ . \square*

Any locally coherent string can be interpreted as a function which associates a face of P_q to every point $q \in Q$ in some “locally coherent” way. This selection must be constant (in the sense that the same face $F_{\sigma,\psi}$ is chosen) in the relative interior of every chamber. No locally coherent string can contain a whole d' -dimensional fiber P_q for some $q \in Q$, because this would imply that P itself is as well contained in that string. Complete fibers P_q of dimension smaller than d' — e. g., for q in the boundary of Q — can always be expressed by non-zero normal vectors. (For example, if a fiber consists only of one vertex any non-zero vector will do the job.) Hence, we will interpret the selection functions as functions from Γ to $S^{d-d'-1}$, where $\psi_\sigma \in S^{d-d'-1}$ induces a proper face of a fiber over σ and therefore a proper face of P .

The following criterion (see Billera, Kapranov & Sturmfels [4] for the case $d' = 1$) describes the admissible selection functions in terms of normal cones.

Proposition 2.6 *A function*

$$\psi : \begin{cases} \Gamma & \rightarrow S^{d-d'-1} \\ \sigma & \mapsto \psi_\sigma \end{cases}$$

defines a locally π -coherent string of Q via

$$\mathcal{F}(\psi) := \{ F_{\sigma,\psi_\sigma} \mid \sigma \in \Gamma \}$$

if and only if for all $\sigma, \tau \in \Gamma$ with $\tau < \sigma$ one has

$$\text{relint}[\psi_\sigma]_\sigma \subseteq \text{relint}[\psi_\tau]_\tau.$$

Furthermore, every locally coherent string arises from a selection function ψ in this way. Two functions ψ and ψ' define the same string, $\mathcal{F}(\psi) = \mathcal{F}(\psi')$, if and only if $[\psi_\sigma]_\sigma = [\psi'_\sigma]_\sigma$ holds for all $\sigma \in \Gamma$. \square

The proof is a careful check of definitions, where Lemma 2.1 yields the necessary details.

Definition 2.7 A function ψ as in Proposition 2.6 is called *locally coherent*. Two functions ψ, ψ' are *equivalent* if they define the same locally coherent string. In this case we write

$$[\psi] = [\psi']$$

for their equivalence class. \square

Because of Lemma 2.4 the crucial function values are just those over the chambers of maximal dimension.

Proposition 2.8 *The cone condition in Proposition 2.6 is equivalent to the following “pairwise cone condition:”*

$$[\psi_{\sigma_1}]_{\sigma_1 \cap \sigma_2} = [\psi_{\sigma_2}]_{\sigma_1 \cap \sigma_2}$$

for all d' -dimensional chambers $\sigma_1, \sigma_2 \in \Gamma$ such that $\sigma_1 \cap \sigma_2 \neq \emptyset$. Any function that respects the pairwise cone condition for the chambers of dimension d' can be completed to a locally coherent function. \square

Figure 3 illustrates Propositions 2.6 and 2.8 for the situation $d = 3$ and $d' = 1$.

3 Validity in low codimension

In this section we prove Theorem 1.4, by presenting an explicit retraction of the following models of the order complexes of $\omega(P, \pi)$ and $\omega_{\text{coh}}(P, \pi)$, namely

$$\Omega = \left\{ \psi \in (S^1)^\Gamma \mid [\psi_\sigma]_\tau = [\psi_\tau]_\tau \quad \text{for all } \tau \leq \sigma \in \Gamma \right\},$$

and

$$\Omega_{\text{coh}} = \left\{ \psi \in (S^1)^\Gamma \mid \psi_\sigma = \psi_\tau \quad \text{for all } \tau, \sigma \in \Gamma \right\}.$$

The topology of the order complexes coincides with the topology induced by the canonical metric on $\Omega, \Omega_{\text{coh}} \subseteq (S^1)^\Gamma$, induced from $(S^1)^\Gamma$ viewed as a product of copies of the metric space S^1 .

Let $\sigma \in \Gamma$. From now on we call two values ψ_1 and ψ_2 in S^1 *locally coherent with respect to σ* , if

$$[\psi_1]_\sigma = [\psi_2]_\sigma. \tag{1}$$

A function

$$\psi : \Gamma \rightarrow S^1$$

defines a locally coherent string if and only if all function values of intersecting chambers are pairwise locally coherent with respect to the intersection of their preimages. (This is the pairwise cone condition of Proposition 2.8.)

The crucial observation is that in codimension 2 this local coherence property reduces to a distance property for function values in (the universal cover of S^1 : if we replace two locally coherent function values by values in the closed interval they span, then they stay locally coherent. In higher codimension this fails in general.

Proof: (of Theorem 1.4 in seven steps)

Step 1: From now on we write q_σ for the *barycenter* of the chamber $\sigma \in \Gamma$. For a function

$$\psi : \begin{cases} \Gamma & \rightarrow S^1 \\ \sigma & \mapsto \psi_\sigma \end{cases}$$

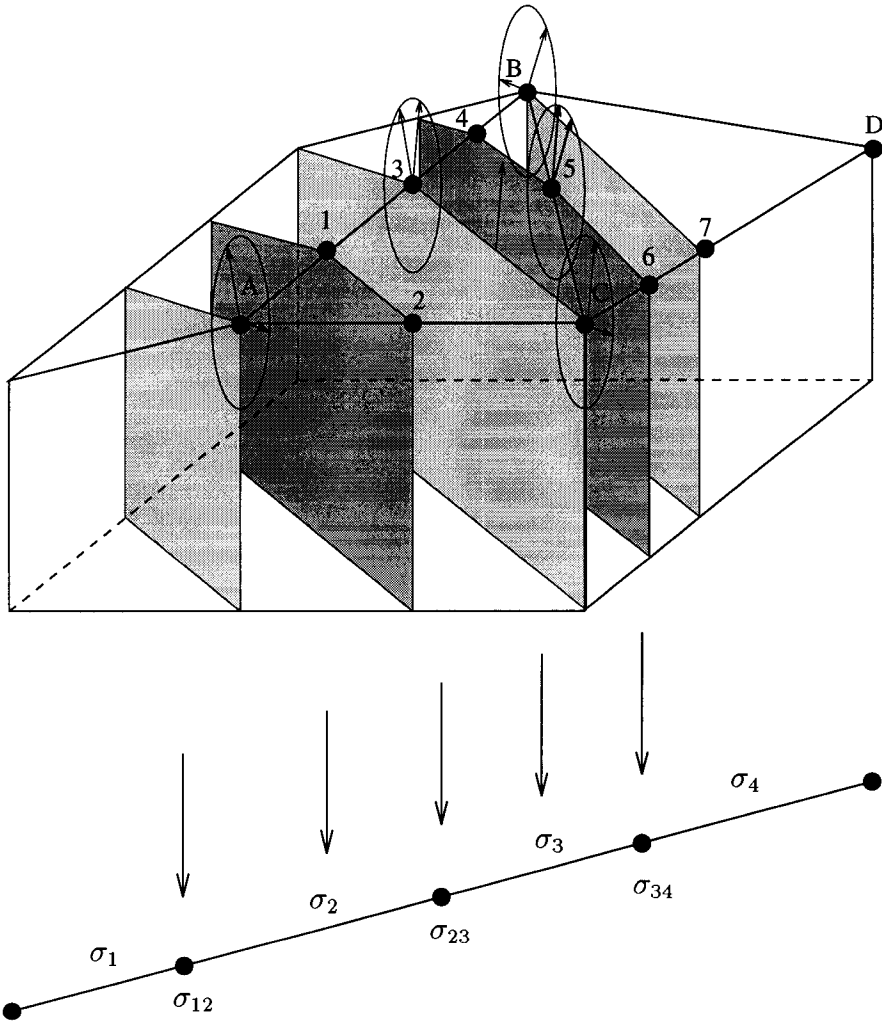

Figure 3: The pairwise cone condition. For example, a choice of 1 over σ_2 and 4 over σ_3 is locally coherent and would imply the choice of 3 over σ_{23} . If 2 is chosen over σ_2 then 4 is not a consistent choice over σ_3 . However, in this case 5 or 6 are “good choices” over σ_3 — with respect to the pairwise cone condition — which both determine C over σ_{23} .

that defines a locally coherent string let

$$\widehat{\psi} : Q \rightarrow S^1$$

be the unique piecewise linear function on the barycentric subdivision $sd(\Gamma)$ of Γ with

$$\widehat{\psi}(q_\sigma) = \psi_\sigma$$

for all chambers $\sigma \in \Gamma$. Here “piecewise linear” means that whenever q is in the simplex spanned by the barycenters of the chambers σ_i , $i = 1, \dots, k$, with barycentric coordinates $\lambda_1, \dots, \lambda_k \geq 0$ and $\sum_{i=1}^k \lambda_i = 1$, its function value is given by

$$\widehat{\psi}(q) = \frac{\sum_{i=1}^k \lambda_i \widehat{\psi}(q_{\sigma_i})}{\|\sum_{i=1}^k \lambda_i \widehat{\psi}(q_{\sigma_i})\|}.$$

This yields a well-defined continuous function: the function ψ defines a locally coherent string and thus the function values on pairwise adjacent chambers lie inside some open hemisphere in S^1 .

Step 2: For the rest of the proof let σ_0 be a fixed chamber of Γ , $\psi : \Gamma \rightarrow S^1$ a locally coherent function, and $\psi_0 := \psi_{\sigma_0}$ its value for σ_0 . For $\lambda \in S^1$ let

$$\Phi_\lambda : \begin{cases} \{ z \in \mathbf{C} \mid \|z\| = 1 \} & \rightarrow S^1 \\ 1 & \mapsto \lambda \end{cases}$$

be an isometry that coordinatizes S^1 . Let

$$w : [0, 1] \rightarrow Q$$

be a path in Q that starts at q_{σ_0} . Then

$$\widehat{\psi}_*(w) : \begin{cases} [0, 1] & \rightarrow S^1 \\ t & \mapsto (\widehat{\psi} \circ w)(t) \end{cases}$$

is a path in S^1 that starts at ψ_0 .

Step 3: Let

$$p : \begin{cases} \mathbf{R} & \rightarrow \{ z \in \mathbf{C} \mid \|z\| = 1 \} \\ t & \mapsto \exp(2\pi it) \end{cases}$$

be the universal covering of $\{ z \in \mathbf{C} \mid \|z\| = 1 \}$ and let

$$p_\lambda : \begin{cases} \mathbf{R} & \rightarrow S^1 \\ t & \mapsto (\Phi_\lambda \circ p)(t) \end{cases}$$

be the universal covering of S^1 where the parameter λ describes different coordinate systems on S^1 . For a path

$$u : [0, 1] \rightarrow S^1$$

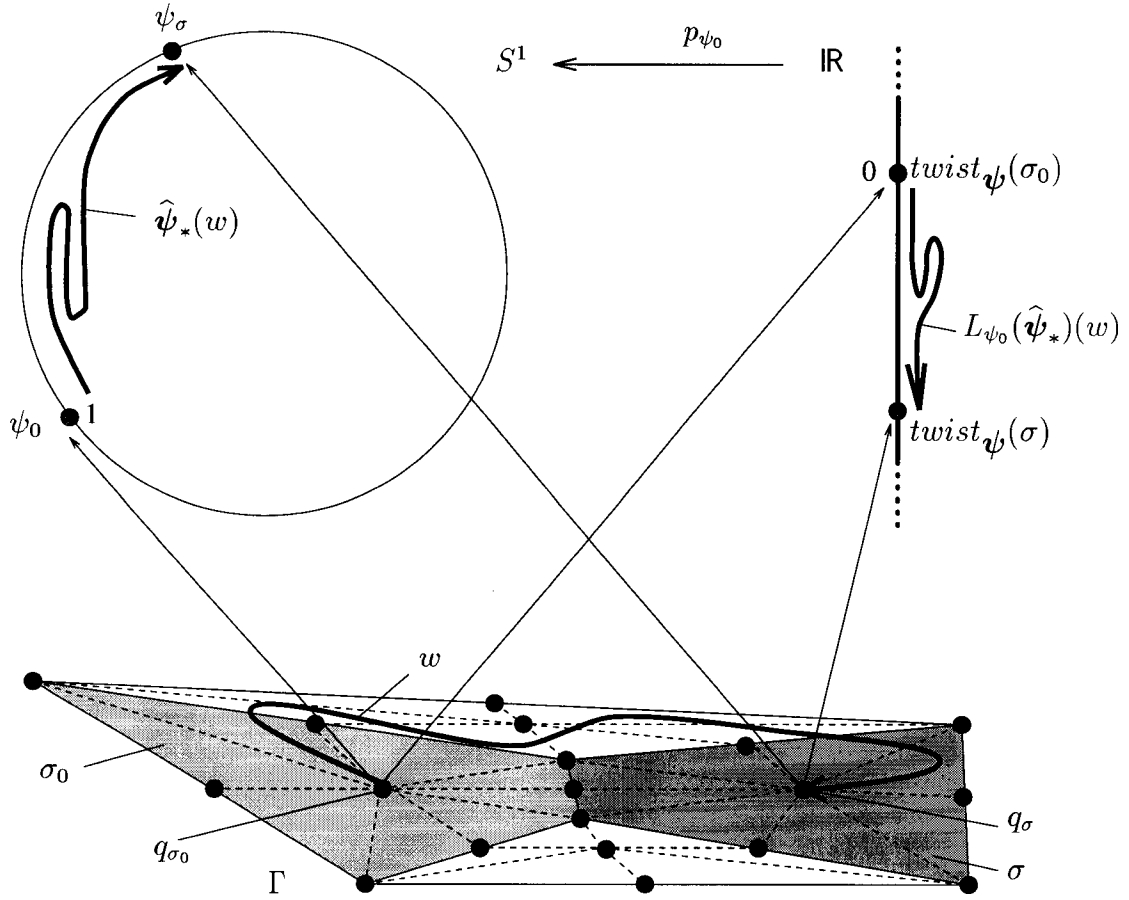

Figure 4: The twist of σ

with $u(0) = 1$ let

$$L_\lambda(u) := L_{p_\lambda}(u, 0) : [0, 1] \rightarrow \mathbb{R}$$

its lifting with $L_\lambda(u)(0) = 0$. We know from the theory of coverings that liftings of paths that are homotopic relative $\partial[0, 1]$ have the same endpoint.

Step 4: We will now lift the “distance” between the considered function values to \mathbb{R} in order to get maximum and minimum values.

Definition 3.1 We define the *twist of ψ* to be the following function:

$$\text{twist}_\psi : \begin{cases} \Gamma & \rightarrow \mathbb{R} \\ \sigma & \mapsto L_{\psi_0}(\hat{\psi}_*)(w)(1), \end{cases} \quad (2)$$

where $w : [0, 1] \rightarrow Q$ is a path from q_{σ_0} to q_σ . □

In other words: coordinatize S^1 properly, take a path from the barycenter of σ_0 to the barycenter of σ , consider the corresponding path induced by the

piecewise linear extension $\widehat{\psi}$ of ψ , and take the endpoint of its lifting to \mathbb{R} . This is well-defined by step 3 because all paths in Q are homotopic. From the definition we get that $\text{twist}_{\mathcal{P}}(\sigma_0) = 0$. Figure 4 shows the twist of the chamber σ .

A locally coherent string is globally coherent if and only if it can be described by a function ψ with $\text{twist}_{\mathcal{P}}(\Gamma) = \{0\}$. In addition we have $p_{\psi_0} \circ \text{twist}_{\mathcal{P}} = \psi$, which makes it possible to recover the function ψ from its twist or to define a new function ψ' by simply changing the twist of ψ (with twist of σ_0 unchanged) and projecting it via p_{ψ_0} .

Step 5: The following lemma shows that local coherence in this special case is preserved under “pushing together” lifted function values — this is the crucial point that cannot be generalized to higher codimension. The proof is just checking definitions by using suitable paths for computing twists.

Lemma 3.2 *Let ψ_{σ_1} and ψ_{σ_2} be locally coherent with respect to $\sigma_1 \cap \sigma_2$ and let, without loss of generality, $\text{twist}_{\mathcal{P}}(\sigma_1) < \text{twist}_{\mathcal{P}}(\sigma_2)$. Then for each $\lambda \in S^1$ each pair of values ψ_1, ψ_2 contained in the arc*

$$p_{\lambda}([\text{twist}_{\mathcal{P}}(\sigma_1), \text{twist}_{\mathcal{P}}(\sigma_2)]) \subset S^1$$

is locally coherent with respect to $\sigma_1 \cap \sigma_2$ as well. □

If a twist is extremal, then there is only one direction in \mathbb{R} with other twist values. That means we can “retwist” all chambers that yield this extremal value until their twist meets the next occurring different twist. So at the next step we will introduce a “twist cutoff” homotopy.

Step 6: Let $M(\psi)$ be the maximum of all absolute values of ψ -twists taken over all chambers $\sigma \in \Gamma$. Define

$$\text{twist}_{\mathcal{P}}(\sigma, t) : \begin{cases} \Gamma \times [0, 1] & \rightarrow \mathbb{R} \\ (\sigma, t) & \mapsto \max\{\min\{\text{twist}_{\mathcal{P}}(\sigma), tM(\psi)\}, -tM(\psi)\}. \end{cases}$$

Step 7: Now we are in position to define the final “retwist”-homotopy. Let

$$\psi_t : \begin{cases} \Gamma \times [0, 1] & \rightarrow S^1 \\ (\sigma, t) & \mapsto p_{\psi_0}(\text{twist}_{\mathcal{P}}(\sigma, t)). \end{cases}$$

Then $\psi_1(\sigma) = \psi_{\sigma}$ and $\psi_0(\sigma) = \psi_0$ for all $\sigma \in \Gamma$. Hence, $\psi_1 = \psi \in \Omega$ and $\psi_0 \in \Omega_{\text{coh}}$. This yields the desired retraction

$$H : \begin{cases} \Omega \times [0, 1] & \rightarrow S^1 \\ (\psi, t) & \mapsto \psi_t \end{cases}$$

with

$$H(\Omega, 1) = \text{id}_{\Omega} \quad \text{and} \quad H(\Omega, 0) = \Omega_{\text{coh}}.$$

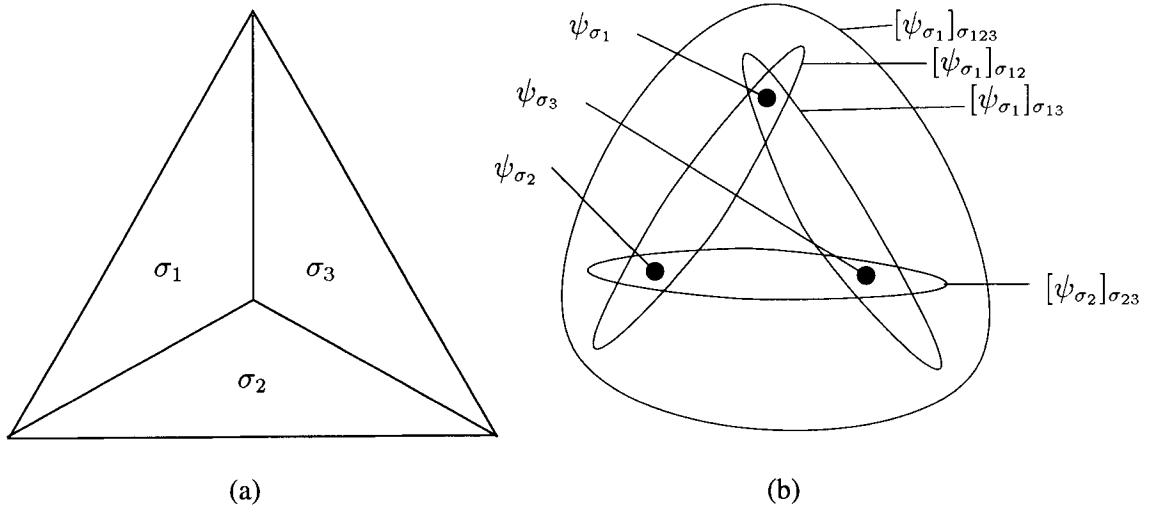

Figure 5: A really simple chamber complex (a) and a generic picture of a “locally coherent” choice of function values on this complex (b).

This retraction is continuous in t by definition. It is continuous in ψ because it contracts distances between functions according to the maximum metric. \square

This proof and the proof of Billera, Kapranov & Sturmfels [4] suggest a duality between the geometric situations in the case $\dim(Q) = 1$ and the case $\dim(P) - \dim(Q) = 2$, as one would expect from an oriented matroid perspective (see also Billera, Gel’fand & Sturmfels [3]): in the case of dimension 1 the polytope Q is linearly ordered and therefore has a “maximum chamber” with local coherence condition only in one direction. The retraction can start at this chamber moving its function value to that of the next adjacent chamber, no matter what the dimension of the image sphere is. In the case of codimension 2 the chambers can yield a very complicated structure of local coherence conditions between their function values, but in this case the lifting of the image of this structure can be retracted in \mathbb{R} easily starting from its boundary, i. e., from the extremal values.

Analysis of the key points in the proof of Theorem 1.4 also led us to the crucial structures for the counterexamples in Sections 4 and 5.

4 How to construct a counterexample

In this section we introduce the main idea for the construction of a counterexample in dimension $\dim(Q) = 2$ and codimension $\dim(P) - \dim(Q) = 3$.

We start with a configuration of three two-dimensional chambers $\sigma_1, \sigma_2, \sigma_3$ that form a subdivision Γ of Q (see Figure 5(a)). The corresponding edges in the

boundary of Q are τ_1 , τ_2 , and τ_3 . We denote $\sigma_i \cap \sigma_j$ by σ_{ij} , and thus the inner vertex $\sigma_1 \cap \sigma_2 \cap \sigma_3$ by σ_{123} . Analogously, we set $\tau_i \cap \tau_j =: \tau_{ij}$.

We want to construct functions $\psi : \Gamma \rightarrow S^2$ that satisfy the “local coherence condition” (Proposition 2.6) with respect to the fiber structure of some polytope projection. First we assign to each σ_i a fixed value ψ_{σ_i} in S^2 such that the cone spanned by the ψ_{σ_i} in $(\mathbb{R}^3)^*$ is full-dimensional. Since ψ ought to be locally coherent this leads to several restrictions on the possible structures of the normal fans over the chambers.

There is a consistent choice for $\psi_{\sigma_{12}}$ only if ψ_{σ_1} and ψ_{σ_2} lie in the same open cone of the normal fan over $\text{relint}(\sigma_{12})$. In general, this open cone (which describes the correct selections for $\psi_{\sigma_{12}}$) does not contain ψ_{σ_3} . These cones are the crucial ones because for local coherence at the inner vertex σ_{123} , we just have to choose a vector in the open cone of the normal fan over σ_{123} that contains the rest of the configuration, which is always possible (compare Lemma 2.2). The generic topological picture of the situation in the sphere S^2 is as in Figure 5(b), which is a superposition of cones from the normal fans over σ_{ij} and σ_{123} .

If the vectors ψ_{σ_i} are in general position with respect to some fiber structure, then the locally π -coherent string \mathcal{F}_0 they determine in a polytope projection that induces this fiber structure is tight. In the following we describe what “has to go wrong” to get a fiber structure in which this tight string is not dominated by a non-tight one $\mathcal{F} > \mathcal{F}_0$. (In this case the tight string *is stuck*).

To get from \mathcal{F}_0 to \mathcal{F} , we have to move at least one of the vectors ψ_{σ_i} to more special position, that is, to the boundary of the normal cone it lies in. One can now see that for every movement of a function value of a maximal chamber — say ψ_{σ_1} — to a face of the normal cone associated with an edge, say $\psi_{\sigma_{12}}$, requires a movement of the other normal vector — here ψ_{σ_2} — contained in that cone to the *same* face in order to stay locally coherent.

The idea is now to produce a configuration of normal cones of the fibers such that for each cone corresponding to the starting values of the function ψ no face is reachable by both the function values of the maximal chambers in a way such that the intermediate functions stay locally coherent.

Consider the “basket ball” with three segments in Figure 6(a): the normal fan of a triangle in \mathbb{R}^3 . We take three perturbed copies of this configuration such that the superposition locally looks as in Figure 6(b). The function values chosen as in the picture are pairwise locally coherent because ψ_{σ_1} and ψ_{σ_2} lie in the same cone $[\psi_{\sigma_1}]_{\sigma_{12}}$ over σ_{12} , and so on. Locally, i. e., inside the border, there is no possibility to push the function values to more special position without violating the pairwise cone condition.

Try, for example, to move ψ_{σ_1} to a face of $[\psi_{\sigma_1}]_{\sigma_{12}}$ before you reach a face of $[\psi_{\sigma_1}]_{\sigma_{13}}$, as drawn in the picture. Then ψ_{σ_2} has to move to the same face — but then it has to pass over a face of $[\psi_{\sigma_2}]_{\sigma_{23}}$ in the meantime, so ψ_{σ_3} has to pass over that same face. But then ψ_{σ_1} should have passed a face of $[\psi_{\sigma_1}]_{\sigma_{13}}$ before having reached any face of $[\psi_{\sigma_1}]_{\sigma_{12}}$: a contradiction. In the same manner inside

the border all possibilities of moving function values over the 2-chambers fail. Hence this provides an obstruction for homotopies on the starting function ψ which we call the “basket ball obstruction”.

Using the opposite side of the sphere a movement may in fact be possible. But the local property will be enough for the following innocent-looking construction which is illustrated in Figure 7.

- Let $\pi : \mathbb{R}^5 \rightarrow \mathbb{R}^2$ be the projection to the last two coordinates.
- Put three triangles into \mathbb{R}^5 in the following way: each triangle projects down to one vertex of the triangle Q , such that the superposition of their normal fans in \mathbb{R}^3 (basket balls!) looks like the basket ball obstruction.
- Let \widehat{P}^{deg} be their convex hull in \mathbb{R}^5 . Up to now the normal fan over σ_{123} is the common refinement of the three basket balls (Corollary 2.5).
- Position a single vertex into \mathbb{R}^5 such that it projects to the 0-cell σ_{123} in the center of Γ . The resulting fiber over σ_{123} will just be the convex hull of the old fiber over σ_{123} and the new vertex. Choose the new vertex v in such a way that its normal cone in the fiber contains the local basket ball configuration from Figure 6(b). (From the primal point of view we put the vertex “beyond” those faces of the fiber that have the local basket ball configuration as normal cones. Hence, in the new normal fan over σ_{123} the local basket ball configuration is replaced by the normal cone of the new vertex.) The resulting polytope $P^{\text{deg}} = \text{conv}(\widehat{P}^{\text{deg}}, v)$ has 10 vertices.
- Because of Proposition 2.2 the normal fans over the edges σ_{ij} of Γ are the common refinement of the normal fan over σ_{123} and the normal fan over the corresponding vertex of Q . Over a vertex of Q there is one basket ball and over σ_{123} there is a fan that contains a cone that “locks” the basket ball obstruction into one cone.
- Define the function values on σ_i as in Figure 6(b) and the function values on σ_{ij} somewhere inside the corresponding cones $[\psi_{\sigma_i}]_{\sigma_{ij}} = [\psi_{\sigma_j}]_{\sigma_{ij}}$.
- Complete this function on the boundary of Q (Proposition 2.8). This yields a tight locally coherent string that is not dominated by a coarser one, i. e., an isolated element in $\omega(P, \pi)$ (see above). \square

In Section 5 we will present a version of P^{deg} with explicit coordinates in \mathbb{R}^5 . Moreover, we will slightly perturb the vertices of P^{deg} to get a simplicial, non-degenerate counterexample P . For each of them we will provide another, simple way to see that it violates the Generalized Baues Conjecture.

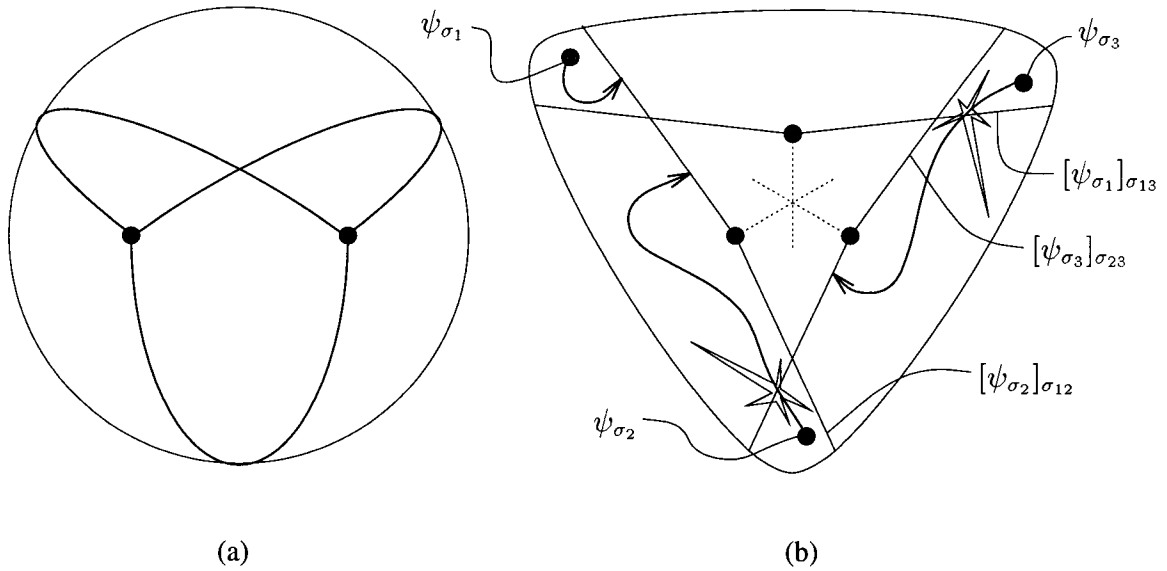

Figure 6: The “basket ball obstruction”.

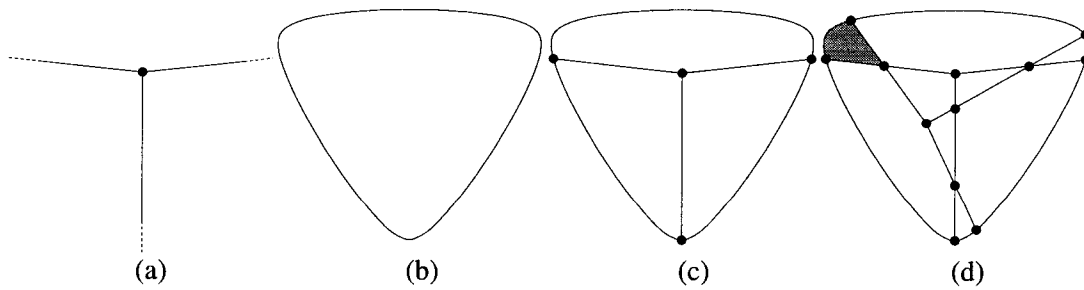

Figure 7: A part of the normal fan over the vertex τ_{12} of Q (a), over σ_{123} (b), over the corresponding edge σ_{12} (c), and over the adjacent 2-dimensional chamber σ_1 (d). If ψ_{σ_1} is chosen in the interior of the shaded cone, and if ψ_{σ_2} and ψ_{σ_3} are chosen analogously with respect to the rotational symmetry we get the basket ball obstruction known from Figure 6.

5 An explicit counterexample

Throughout this section we use homogeneous coordinates in order to get a nice threefold rotational symmetry for Q^{deg} and Q without square roots. We use projections that delete the first three coordinates. The following list contains as rows the (homogeneous) coordinates for ten points in \mathbb{R}^5 in convex position.

```

DIM = 6
CONE_SECTION
( 1)  1      0      0      1      0      0
( 2)  0      3/2    1      1      0      0
( 3)  0      1      3/2    1      0      0

( 4)  0      1      0      0      1      0
( 5)  1      0      3/2    0      1      0
( 6)  3/2    0      1      0      1      0

( 7)  0      0      1      0      0      1
( 8)  3/2    1      0      0      0      1
( 9)  1      3/2    0      0      0      1

(10)  2      2      2      1/3    1/3    1/3
END

```

The first nine rows correspond to the three triangles of the abstract construction in Section 4, the tenth one represents the additional vertex. The chamber complex of the projection to the last three coordinates is as in Figure 5(a). The normal fans of the three triangles in \mathbb{R}^3 form the basket ball obstruction. The additional vertex yields the midpoint of the chamber complex and bounds the obstruction over the edges of the chamber complex. Figure 8 is an attempt to visualize the construction.

The above listing is in correct input format for the PORTA program by Christof [8]. This program easily produces a complete list of all 36 facets of P , and the vertex-facet incidence matrix in Figure 10.

The following tight locally coherent string — where the faces $F_1^{\text{deg}}, F_2^{\text{deg}}, F_3^{\text{deg}}$ are given by their vertices labelled as in the listing above — will correspond to the three given function values in Figure 6.

$$\mathcal{F}_0^{\text{deg}} := \{(1, 4, 10), (4, 7, 10), (7, 1, 10)\}$$

where the actual string contains all the nonempty faces of the three triangles that are listed.

Once we have this, it is very easy to see independently from Section 4 that this is a counterexample to the Generalized Baues Conjecture. To form a strictly coarser string we must replace at least one of the faces $F_1^{\text{deg}}, F_2^{\text{deg}}, F_3^{\text{deg}}$ in $\mathcal{F}_0^{\text{deg}}$

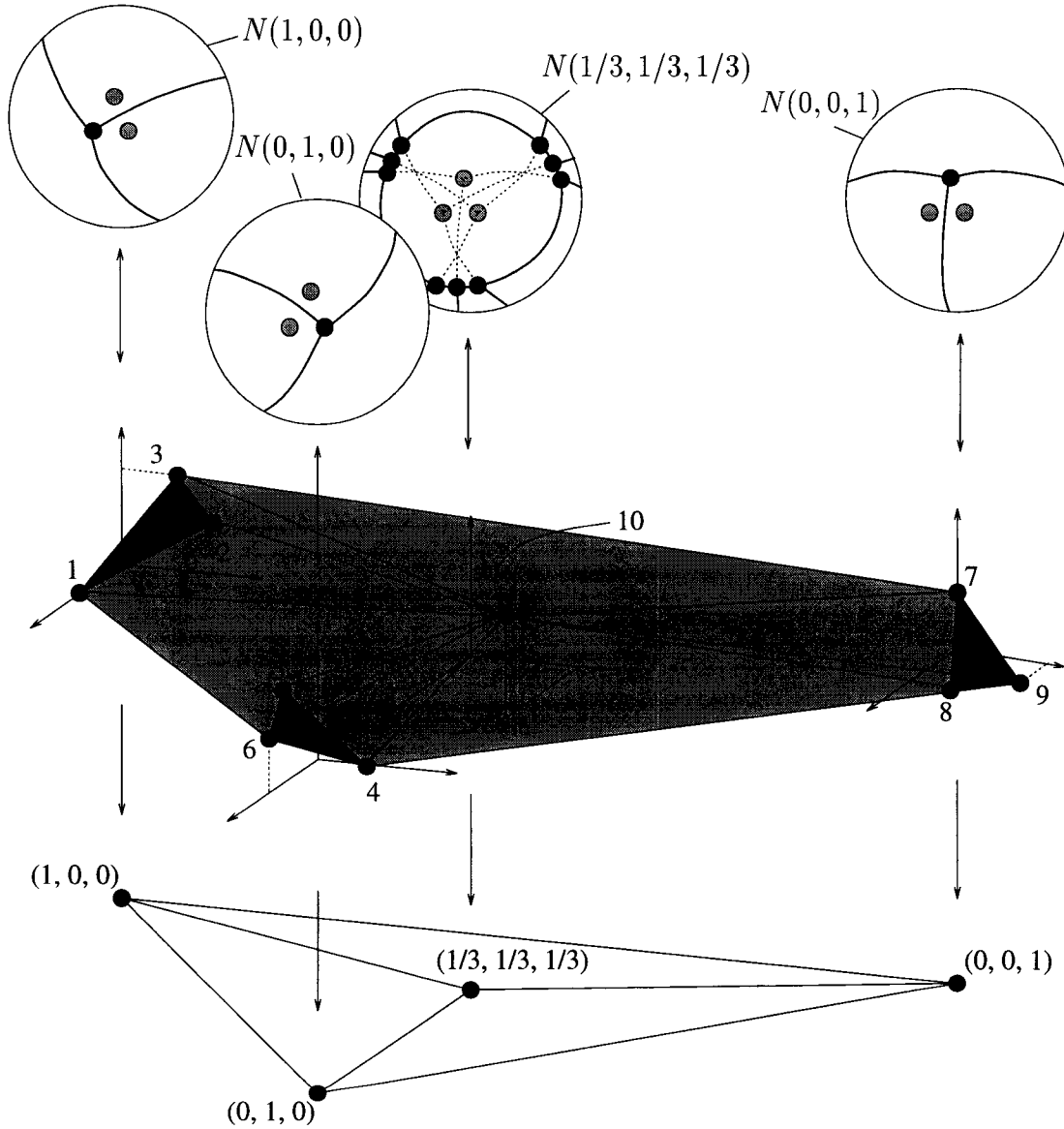

Figure 8: A sketch of $\pi^{\text{deg}} : P^{\text{deg}} \rightarrow Q^{\text{deg}}$: Over each vertex of Q^{deg} one perturbed basket ball is positioned. Adding the tenth vertex in the middle provides a bounding cone around the basket ball obstruction. (The light-shadowed vertices and the dotted lines are drawn to indicate the relative cone positions between the fans.) The 5-polytope P^{deg} is the convex hull of the three dark triangles — each of them in an \mathbb{R}^3 over one vertex of Q^{deg} — and the additional vertex (10) in the middle.

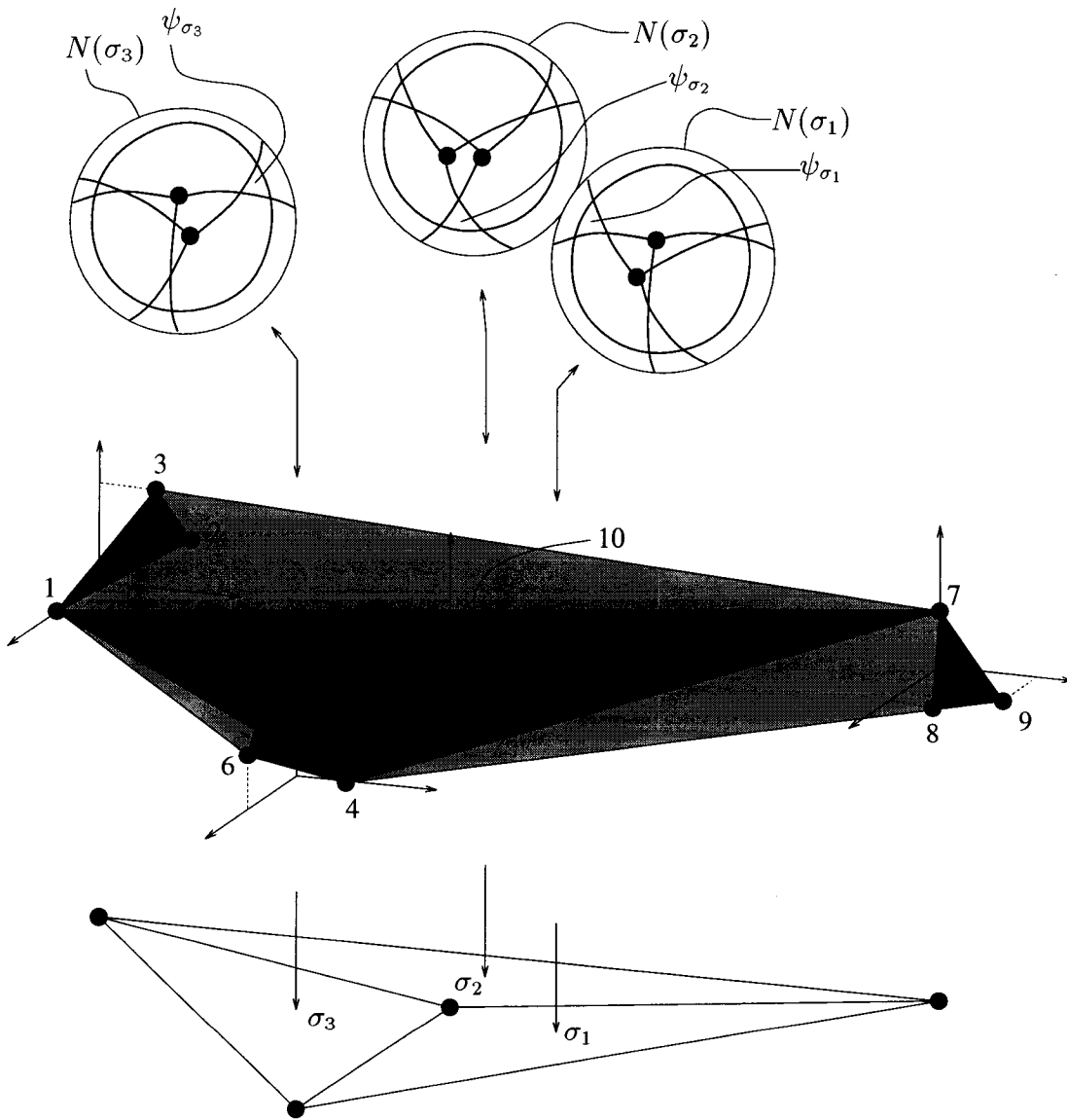

Figure 9: The medium-dark triangles correspond to the isolated locally coherent string $\{(1, 4, 10), (4, 7, 10), (7, 1, 10)\}$ that is defined by the function values ψ_{σ_1} , ψ_{σ_2} , and ψ_{σ_3} for the chambers σ_1 , σ_2 , and σ_3 .

strong validity table :

\ P				
\ O				
I \ I				
N \ N		1	6	#
E \ T				
Q \ S				
S \				
\				

1		.***. *.** :	5		19		..*** *.** :	5
2		*...* **..* :	5		20		*..* *.*** :	5
3		*..* .**** :	5		21		*..* *.** :	5
4		...* .**** :	5		22		**..* ...** :	5
5		..*.. .**** :	5		23		*...* ***.* :	5
6		...** *...* :	5		24		*..* *.*** :	5
7		.*** *...* :	5		25		...* *.*** :	5
8		***.. ..*.* :	5		26		.**** :	5
9		***.. *...* :	5		27		...* ***.* :	5
10		...** .**** :	6		28		*..* *...* :	5
11		***.. .**** :	6		29		...* *.*** :	5
12		.**** *... :	6		30		**... .**** :	5
13		*.*** *.** :	5		31		.**** *.** :	5
14		**..* ..*.* :	5		32		*...* **... :	5
15		*..* ***.. :	5		33		*..* .**** :	5
16		...** *.** :	5		34		...* *.*** :	5
17		*..* ..*.* :	5		35		...* .**** :	5
18		**..* *...* :	5		36		...* *...* :	5
							
					#		21121 12112	
		\/					06606 60667	

Figure 10: The vertex-facet incidence matrix of P^{deg} .

by a face \hat{F}_i^{deg} of P^{deg} that contains F_i^{deg} . This can be described by adding one or more vertices to F_i^{deg} such that we get a face. From the definition of a locally coherent string it follows that a new vertex v has to be added (combinatorially) to all faces of $\mathcal{F}_0^{\text{deg}}$ whose projection contains $\pi(v)$.

From the vertex-facet incidence matrix we can compute for each face F in $\mathcal{F}_0^{\text{deg}}$ all sets V of vertices in $P^{\text{deg}} \setminus F$ such that $\text{vert}(F) \cup V$ are the vertices of a face in P^{deg} . They correspond exactly to the faces in the *link of F in P^{deg}* denoted by $lk(F) := lk_{P^{\text{deg}}}(F)$. It turns out that all links are 4-gons, namely

$$\begin{aligned} lk(1, 4, 10) &= (2 - 9 - 8 - 6 - 2), \\ lk(4, 7, 10) &= (5 - 3 - 2 - 9 - 5), \\ lk(7, 1, 10) &= (8 - 6 - 5 - 3 - 8). \end{aligned}$$

Because of the rotational symmetry it suffices to test the vertices in $lk(1, 4, 10)$. For example adding vertex 2 to the face $(1, 4, 10)$ requires adding vertex 2 to the face $(7, 1, 10)$ because $\pi(7, 1, 10)$ contains $\pi(2)$ — but vertex 2 is not contained in the link of $(7, 1, 10)$. Analogous contradictions occur in all other cases. This proves that $\mathcal{F}_0^{\text{deg}}$ is in fact an isolated element in $\omega(P^{\text{deg}}, \pi)$. This example corresponds exactly to the construction at the end of Section 4. \square

The coordinates of P^{deg} can be slightly perturbed in order to make the projection non-degenerate. We claim that the following listing contains the coordinates of a simplicial, non-degenerate counterexample P .

```

DIM = 6
CONE_SECTION
( 1)  1      0      0      1      0      0
( 2)  0      3/2    1      1     -1/11  -1/21
( 3)  0      1      3/2    1     -1/20  -1/10

( 4)  0      1      0      0      1      0
( 5)  1      0      3/2   -1/21   1     -1/11
( 6) 3/2     0      1     -1/10   1     -1/20

( 7)  0      0      1      0      0      1
( 8) 3/2     1      0     -1/11  -1/21   1
( 9)  1      3/2    0     -1/20  -1/10   1

(10)  2      2      2      1/3     1/3     1/3
END

```

All the vertices of P project to pairwise different points in the plane. We again inspect the vertex-facet incidence matrix, see Figure 12. Each facet has exactly five vertices, so P is a simplicial polytope. Consider the chamber complex of the projection in Figure 11 — an exact drawing produced by the computer which

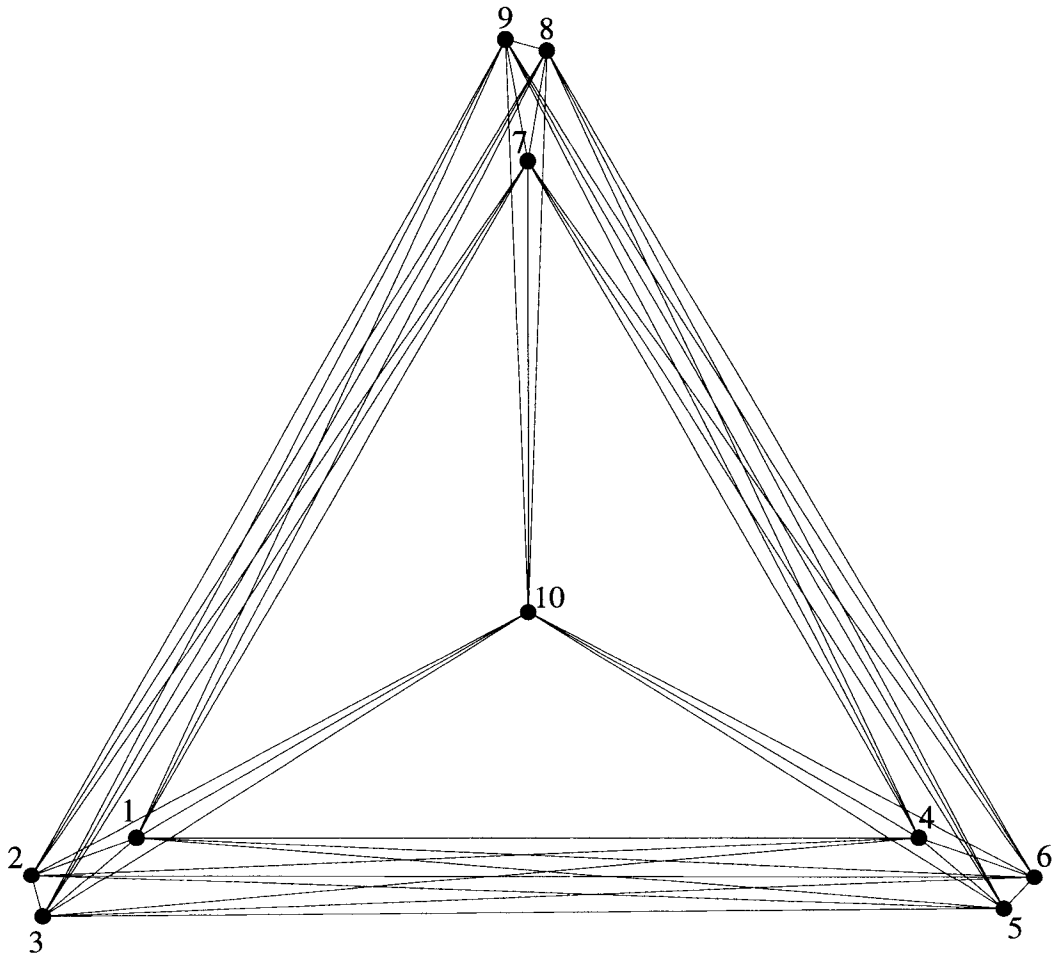

Figure 11: The chamber complex of π .

strong validity table :

\ P			
\ O			
I \ I			
N \ N	1	6	#
E \ T			
Q \ S			
S \			
\			
1	.****	*....	: 5
2	*.***	*....	: 5
3	****.	*....	: 5
4	*...*	**...	: 5
5	*.***	*....	: 5
6	****.	*....	: 5
7	*...*	****.	: 5
8	...**	**.*.	: 5
9	**.*.	*...*	: 5
10	***..	*...*	: 5
11	***..	****.	: 5
12	...*	****.	: 5
13	*...*	****.	: 5
14*	****.	: 5
15	*...*	****.	: 5
16	.*****	: 5
17	*...*	*...*	: 5
18	*...*	*...*	: 5
19	*...*	*...*	: 5
20	***..	*...*	: 5
21	**.*.	*...*	: 5
	\/		
22	*...*	**...*	: 5
23	*...*	*...*	: 5
24	..***	*...*	: 5
25	.***.	*...*	: 5
26	*....	***.*	: 5
27	*...*	*...*	: 5
28	...**	*...*	: 5
29	...**	*...*	: 5
30	**.*.	...**	: 5
31	*...*	*...*	: 5
32	.***.	*...*	: 5
33	***..	...**	: 5
34	.***.	...**	: 5
35	**...*	...**	: 5
36	...*	*...*	: 5
37	*...*	...**	: 5
38	...*	***.*	: 5
39	...*	*...*	: 5
40	...*	****.	: 5
41	*...*	**.*.	: 5
42	..*..	****.	: 5
		
	#	21221 22122	
		38038 03807	

Figure 12: The vertex-facet incidence matrix of P .

also shows that P is 2-neighborly. The projections of the three faces $(1, 4, 10)$, $(4, 7, 10)$, and $(7, 1, 10)$ do not cover Q . However, for chambers that are not covered we find, for example, the following tight completion:

$$\begin{aligned} \mathcal{F}_0 := & \{(1, 4, 10), (1, 2, 4), (2, 3, 4), (3, 4, 5), \\ & (4, 7, 10), (4, 5, 7), (5, 6, 7), (6, 7, 8), \\ & (7, 1, 10), (7, 8, 9), (8, 9, 1), (9, 1, 2)\}. \end{aligned}$$

This is not an isolated element in $\omega(P, \pi)$, because there are local changes possible on the new faces. For example, the faces $(1, 2, 4)$ and $(2, 3, 4)$ are dominated by $(1, 2, 3, 4)$, etc. However, a local change of $(1, 4, 7)$, $(4, 7, 10)$, or $(7, 1, 10)$, is not possible. To see this, we first check that no facet of P contains more than one of these three faces. Consider again Figure 11. If, without loss of generality, we take any face F in P that contains $(1, 4, 10)$ we observe that some new edge of F projects into the interior of $\pi(4, 7, 10)$ or $\pi(7, 1, 10)$. (The link of $(1, 4, 7)$ is again $(2 - 9 - 8 - 6 - 2)$, etc.) For example, if we replace $(1, 4, 10)$ by $(1, 2, 4, 10)$ — a simplex — the projection of the new edge $(2, 10)$ cuts through the interior of $\pi(7, 1, 10)$. But then we have produced overlapping projections, a contradiction to the fact that every locally coherent string defines a polyhedral subdivision after projection.

We see that *any* locally coherent string in the connected component of \mathcal{F}_0 *must* contain the three faces $(1, 4, 10)$, $(4, 7, 10)$, and $(7, 1, 10)$. But obviously there is the following locally coherent string where the face $(1, 4, 7)$ replaces the three “rigid” faces:

$$\begin{aligned} \mathcal{F}_1 := & \{(1, 4, 7), (1, 2, 4), (2, 3, 4), (3, 4, 5), \\ & (4, 5, 7), (5, 6, 7), (6, 7, 8), \\ & (7, 8, 9), (8, 9, 1), (9, 1, 2)\}. \end{aligned}$$

Thus we conclude that there are at least two connected components in $\omega(P, \pi)$, in contradiction to the Generalized Baues Conjecture. \square

Acknowledgements

We would like to thank Jürgen Richter-Gebert and Nikolai Mnëv for helpful discussions.

References

- [1] J. Frank Adams. On the cobar construction. *Proceedings of the National Academy of Science*, 42:409–412, 1956.
- [2] Hans Joachim Baues. Geometry of loop spaces and the cobar construction. *Memiors of the American Mathematical Society*, 25(230), 1980.

- [3] Louis J. Billera, I. M. Gel'fand, and Bernd Sturmfels. Duality and minors of secondary polyhedra. *Journal of Combinatorial Theory*, B 57:258–268, 1993.
- [4] Louis J. Billera, Mikhail M. Kapranov, and Bernd Sturmfels. Cellular strings on polytopes. *Proceedings of the American Mathematical Society*, 122:549–555, 1994.
- [5] Louis J. Billera and Bernd Sturmfels. Fiber polytopes. *Annals of Mathematics*, 135:527–549, 1992.
- [6] Anders Björner. Essential chains and homotopy types of posets. *Proceedings of the American Mathematical Society*, 402:1179–1181, 1992.
- [7] Anders Björner. Topological methods. In R. Graham, M. Grötschel, and L. Lovász, editors, *Handbook of Combinatorics*. North Holland, Amsterdam, 1995.
- [8] Thomas Christof. Porta — a polyhedron representation transformation algorithm v. 1.2.1. Available from the ZIB electronic library ELIB via elib@zib-berlin.de or by anonymous ftp from [elib.zib-berlin.de](ftp://elib.zib-berlin.de/pub/mathprog), directory /pub/mathprog.
- [9] Barry Joe. Three dimensional triangulations from local transformations. *SIAM Journal of Scientific Statistical Computation*, 10:718–741, 1989.
- [10] Barry Joe. Construction of three-dimensional Delaunay triangulations using local transformations. *Computer Aided Geometric Design*, 8:123–142, 1991.
- [11] Robert D. MacPherson. Combinatorial differential manifolds. In L. R. Goldberg and A. V. Phillips, editors, *Topological Methods in Modern Mathematics: a Symposium in Honor of John Milnor's Sixtieth Birthday*, pages 203–221, Stony Brook NY, 1991. Publish or Perish, Houston TX, 1993.
- [12] Nikolai E. Mnëv and Günter M. Ziegler. Combinatorial models for the finite-dimensional Grassmannians. *Discrete & Computational Geometry*, 10:241–250, 1993.
- [13] Alexander Nabutovsky. Extremal triangulations of manifolds. Preprint, 1994.
- [14] Bernd Sturmfels. Fiber polytopes: A brief overview. In M. Yoshida, editor, *Special differential equations*, pages 117–124. Kyushu University, Fukuoka, 1991.
- [15] Bernd Sturmfels and Günter M. Ziegler. Extension spaces of oriented matroids. *Discrete & Computational Geometry*, 10:23–45, 1993.
- [16] Günter M. Ziegler. *Lectures on Polytopes*, volume 152 of *Graduate Texts in Mathematics*. Springer, New York, 1995.